

Nuheat

ROOF & GUTTER DE-ICING SYSTEM

13mm Self-Regulating Heating Cable

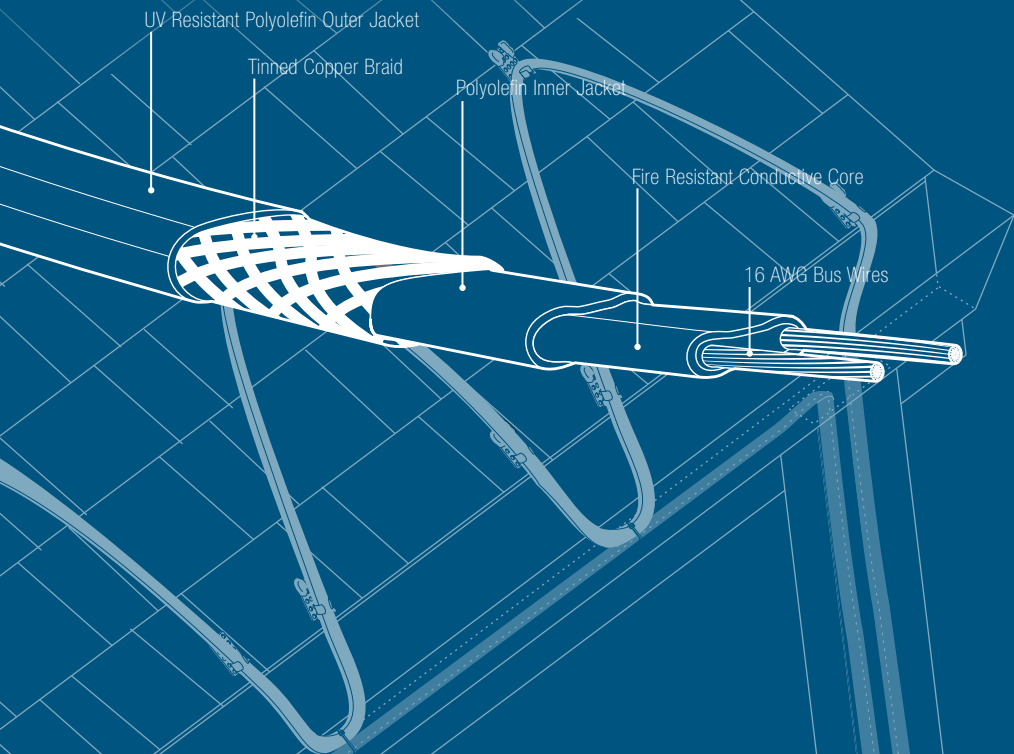

Freeze
Protection
Products

PIPE • ROOF & GUTTER • SLAB



NUHEAT INDUSTRIES LIMITED

© 2010 Nuheat Industries Limited. All rights reserved.

The entire contents of this manual, including but not limited to text, images, and the selection and arrangement of information (collectively the "Materials"), are protected by copyright and other intellectual property laws under the laws of Canada and other countries.

ATTENTION:

- The installation of this heating product shall be in accordance with the manufacturer's instructions and in accordance with the Canadian Electrical Code Part 1 or the National Electrical Code (US) whichever is applicable.
- This equipment shall be installed only by qualified personnel who are familiar with the construction and operation of the apparatus and risks involved.
- Caution should be taken to guard against risk of electric shock, fire and bodily injury during the installation of this equipment.
- Indicate on the electrical panel which circuit is used for the Nuheat Freeze Protection Product.

TABLE OF CONTENTS

SECTION 1: PRE-INSTALLATION

1.1	Important Installation Guidelines	6
1.2	Before You Start	7
1.3	System Components	8
1.4	Insulation & Continuity Tests	12
1.5	Insulation Resistance Table	13
1.6	Warranty Information	14
1.7	Pre-Installation Checks	16

SECTION 2: INSTALLATION

2.1	Gutters	18
2.2	Downspouts	19
2.3	Roof	23
2.4	Post-Installation Checks	28

SECTION 3: ELECTRICAL CONNECTIONS & CONTROLS

3.1	Electrical Connections	30
3.2	Typical Wiring Diagram	31
3.3	Control Options	32
3.4	Repairs and Maintenance	32
3.5	Appendix 1	33

SECTION 1 PRE-INSTALLATION

1.1	IMPORTANT INSTALLATION GUIDELINES	6
1.2	BEFORE YOU START	7
1.21	Tools	7
1.22	Materials	7
1.3	SYSTEM COMPONENTS	8
1.31	Roof & Gutter De-icing System Overview	8
1.32	Roof & Gutter Heating Cable	9
1.33	Power Connections, Splices, End Seals	9
1.34	Snow Controller / Sensor	9
1.35	Roof Clips	10
1.36	Downspout Hangers	11
1.4	INSULATION & CONTINUITY TESTS	12
1.41	Insulation Test	12
1.42	Continuity Test	12
1.5	INSULATION RESISTANCE TABLE	13
1.6	WARRANTY INFO	14
1.61	Warranty Terms	14
1.62	How to Claim this Warranty	14
1.63	Disclaimer	15
1.64	Warranty Coverage	15
1.7	PRE-INSTALLATION CHECKS	16

1.1 IMPORTANT INSTALLATION GUIDELINES

- > Do not energize the heating cable(s) before installation is complete.
- > Ensure bus wires are separated. Bus wires will short if in contact when cables are powered.
- > Cable ends must be terminated with Nuheat end seals. Bus wires cannot be left exposed.
- > Bus wires and cable terminations should be kept dry before, during, and after installation.
- > Ensure drip loops are made to prevent water from trailing into any electrical equipment, junction boxes, or controls.
- > Be careful not to break bus wire strands when isolating bus wires during splice connections. Damaged bus wires can overheat or may cause a short circuit.
- > Only use Nuheat connection components to make splices and/or end terminations. Nuheat connection components are certified and approved for use with Nuheat self-regulating cables.
- > Do not use epoxies or acid-curing silicones to attach roof clips to roof. Epoxies or acid-curing silicones are generally not suitable for exterior roof and gutter applications. Consult a roofing contractor in your area for recommendations on proper adhesives for roof material and environmental conditions.
- > Observe the maximum circuit lengths of the cable (Appendix 1 on page 31) and do not exceed this limit during the installation. Exceeding the maximum circuit lengths will result in breaker trips which will prevent the heating cable from turning on in freezing conditions.
- > Conduct insulation and resistance tests before, during, and after installation. Refer to testing procedures on page 12 of this guide.
- > Testing and visual inspections of the heating cable should be performed after any type of roof maintenance or repair including but not limited to roof/gutter/downspout repair, manual snow removal, and installation/addition of roof features.
- > Ensure gutters and downspouts are free of leaves and other debris prior to each winter season.
- > Materials used for the housing (ie. junction boxes), support or on which the cables are installed shall be grounded in accordance with CSA standard C22.1, section 10.
- > All installations must be in compliance with the following electrical codes:
 - o Articles 426 and 500 of the NEC (National Electrical Code)
 - o Sections 62 and 18 of the CEC (Canadian Electrical Code)

NUHEAT INDUSTRIES AND NEC REQUIRE 30mA EQUIPMENT GROUND-FAULT PROTECTION ON EACH HEATING CABLE BRANCH CIRCUIT.

1.2 BEFORE YOU START

The following tools/materials are required for the Nuheat Roof & Gutter De-icing System installation:

1.21 TOOLS

- > 1000Vdc megohmmeter
- > Multimeter
- > Method to payout/unreel the heating cable
- > Cutting pliers
- > Tools to secure roof clips (if installing heating cable on roof)
 - o Hammer/Drills (if using screws/nails to secure the roof clips)OR
 - o Caulking gun (if using adhesive to secure the roof clips)

1.22 MATERIALS

- > Materials to secure the Nuheat roof clips to the roof and/or gutter (based on the application and installation method):
 - o Suitable adhesive/sealant
 - o Screws/Nails
- > Materials needed for electrical connections
 - o Nuheat approved connection kits
 - o Junction boxes
 - o Suitable conduit for various connections
 - » Between breaker panel and junction boxes
 - » Between junction boxes and control
- > UV cable ties
 - o Only required if heating cable installed on **BOTH** roof and gutters

1.3 SYSTEM COMPONENTS

1.31 ROOF & GUTTER DE-ICING SYSTEM OVERVIEW

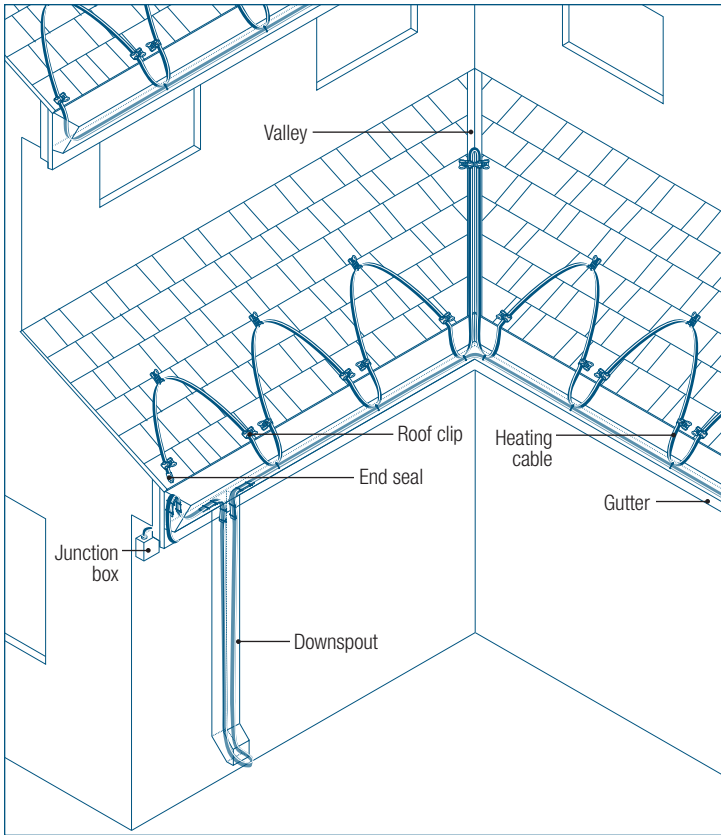

FIGURE 1.31: Roof & Gutter De-icing System

The Nuheat Roof & Gutter De-icing System creates/maintains drain paths to help remove melt water from roof and gutter systems. This will prevent ice dams and ice build-up that can cause extensive damage to roof and gutter systems.

Nuheat Roof & Gutter De-icing System is compatible with:

- > Standard gutter/downspout materials
 - o Metal
 - o Plastic
 - o Wood
- > Standard roof materials
 - o Shake/Shingle
 - o Rubber/Tar
 - o Wood
 - o Metal
 - o Plastic

1.3 SYSTEM COMPONENTS

1.32 ROOF & GUTTER DE-ICING CABLE

Nuheat self-regulating heating cables are installed inside the gutters, downspouts and/or installed on roofs.

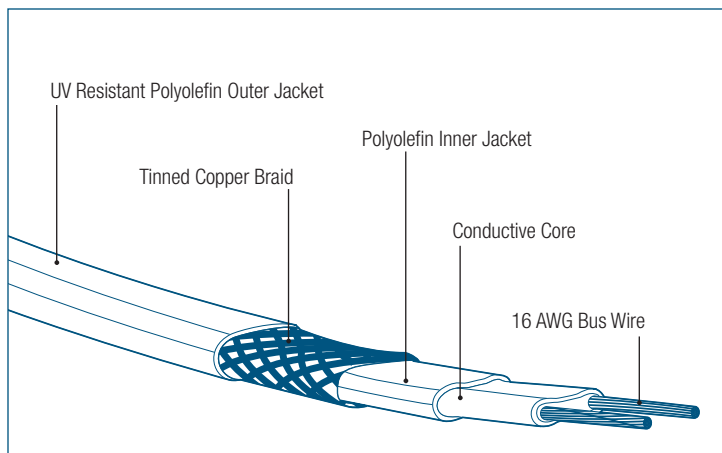

FIGURE 1.32: Roof & Gutter Self-Regulating Heating Cable

1.33 POWER CONNECTIONS, SPLICES, END SEALS

Specific kits are required to connect heating cables to power, splicing/splitting to extend heating cable into downspouts, and sealing cable end(s).

1.34 SNOW CONTROLLER OR THERMOSTATS

Snow controllers or thermostats control when heating cables turn on/off. There are several snow controller and thermostat options with varying levels of customization. More information on snow controllers and thermostats can be found on page 30.

1.3 SYSTEM COMPONENTS

1.35 ROOF CLIPS

The heating cable can be attached to a roof using Nuheat roof clips. Secure Nuheat roof clips to roof using screws, nails or adhesives. If screws or nails are used, weatherproof sealant must cover screws or nail holes to prevent water ingress.

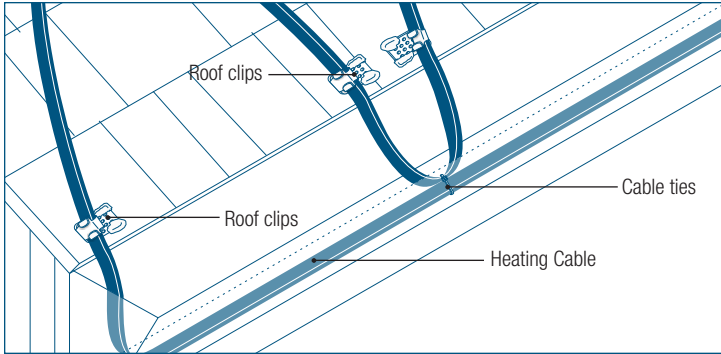

FIGURE 1.35a: Roof Clips

Nuheat roof clips can also be used as spacers inside gutters when multiple runs of cable are used. Secure roof clips to gutter base using weather resistant adhesive.

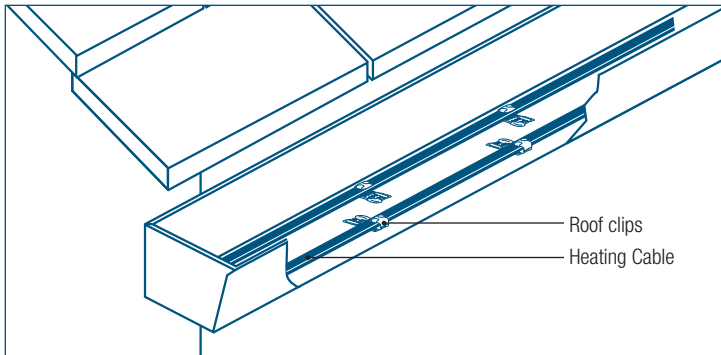

FIGURE 1.35b: Roof Clips

1.3 SYSTEM COMPONENTS

1.36 DOWNSPOUT HANGERS

Nuheat downspout hangers are required to prevent damage to heating cable as it enters/exits the downspout. Downspout hangers can also be used as spacers inside the gutters when multiple runs of heating cable are used.

 **Downspout hangers do not need to be secured to gutters.**

When entering/exiting a downspout, bend downspout hanger to 90° and place over gutter/downspout transition. Run heating cable overtop of hanger and secure using UV resistant cable ties.

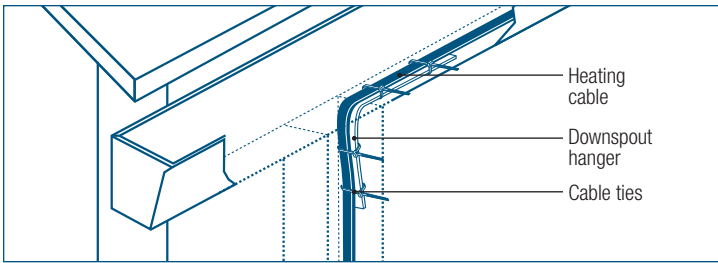

FIGURE 1.36a: Downspout Hanger

When using downspout hangers as spacers in wider gutters, place the hangers at the base of the gutter and angle across gutter width. Run heating cable overtop of hanger and secure to hanger using UV resistant cable ties.

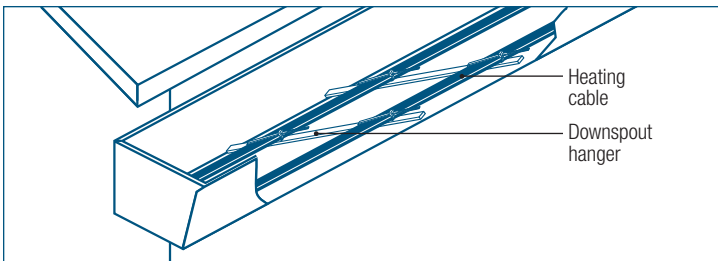

FIGURE 1.36b: Downspout Hangers as Spacers

1.4 INSULATION & CONTINUITY TESTS

Insulation resistance tests must be performed on each circuit before, during and after installation of the Nuheat Roof & Gutter De-Icing System. Insulation resistance readings must be recorded in the tables in Section 1.5

Before performing any tests, disconnect all electrical components to the heating cable including power, thermostats, and contactors. The two bus wires and metal ground braid needs to be separated prior to conducting any tests.

To separate the bus wires and ground braid:

1. Lightly score around and down the outer jacket 3" from the end of the heating cable. Bend heating cable to break jacket at score; peel off outer jacket.
2. Push back braid to loosen. Spread apart braid, bend the heating cable and work it through the opening in the braid.
3. Position braid on one side of the cable and twist into a pigtail.
4. Lightly score around and down the inner jacket 1.5" from the end of the heating cable and remove.
5. Cut down the center of the conductive core and trim away ½" of the conductive core from the tip of the cable exposing the bus wires.

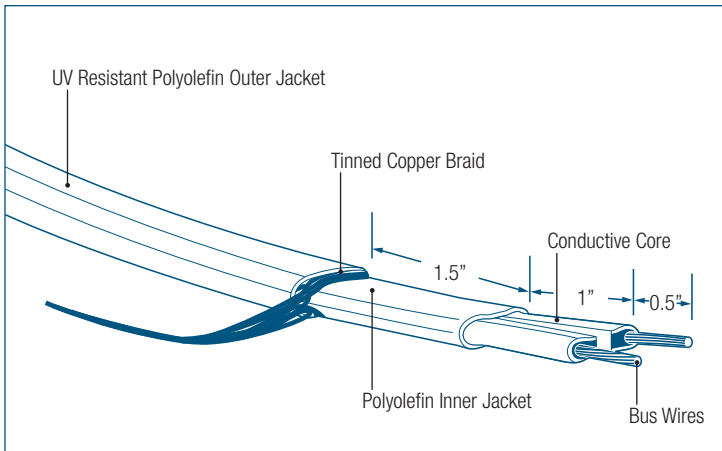

FIGURE 1.4: Separating Heating Cable Bus Wires

1.4 INSULATION & CONTINUITY TESTS

1.41 INSULATION RESISTANCE TEST

1. Set the megohmmeter voltage to 0 Vdc.
2. Connect the negative alligator clip to the metallic braid of the heating cable.
3. Connect the positive alligator clip to the both heating cable bus wires.
4. Turn on the megohmmeter and set the voltage to 500 Vdc.
5. Apply voltage for one (1) minute.
6. Check the resistance reading.
7. Confirm that the resistance is greater than 20 megohms.
8. Record insulation resistance reading in table in Section 1.5.
9. Repeat step 4-7 at 1000 Vdc.
10. Confirm that the resistance value is within +/- 10% of each other regardless of the voltage applied.
11. Record insulation resistance reading in table in Section 1.5.

1.42 CONTINUITY TEST

1. Set the multimeter to measure resistance.
2. Connect the positive alligator clip to one of the bus wires.
3. Connect the negative alligator clip to the other bus wire.
4. Confirm that the resistance reading is less than 3 ohms. Resistance readings of 1000 ohms or greater generally indicate damage to the bus wire or improperly installed connection kits.

1.43 FREQUENCY OF TESTING

Insulation resistance and continuity tests should be performed:

- > Before installing the heating cable
- > After installing connection kits (refer to connection kits instructions)
- > Before installing the thermal insulation
- > Before initial start-up (commissioning)

Testing should also be included as part of regular system inspections, as well as after any maintenance or repair work.

1.43 CIRCUIT LENGTH VERIFICATION TEST

1. Set megohmmeter to measure capacitance and set meter to 200 nF range.
2. Connect positive alligator clip to braid wire.
3. Connect negative alligator clip to both bus wires.
4. Multiply this reading by capacitance factor indicated on the right to determine total circuit length (in feet).

Heating Cable	Capacitance Factor
	ft/nF
13mm	5.3

1.5 INSULATION RESISTANCE TABLE

If the reading on the insulation resistance test does not pass the requirements at any point of the installation, halt installation immediately and contact Nuheat Technical Services at 1.800.778.WARM(9276).

Record heating cable insulation resistance test in the table below and leave with the end user for warranty purposes:

INSULATION RESISTANCE		BEFORE INSTALLING HEATING CABLE	AFTER INSTALLING CONNECTION KITS	BEFORE INITIAL START-UP (COMMISSIONING)
Run 1	@ 500 Vdc			
	@ 1000Vdc			
Run 2	@ 500 Vdc			
	@ 1000Vdc			
Run 3	@ 500 Vdc			
	@ 1000Vdc			
Run 4	@ 500 Vdc			
	@ 1000Vdc			
Run 5	@ 500 Vdc			
	@ 1000Vdc			

Failure to record insulation resistance tests in the above table will void the Nuheat Roof & Gutter De-Icing System warranty.

The Nuheat standard limited warranty for freeze protection products applies to Pipe Freeze Protection and Roof & Gutter De-icing products.

Nuheat self-regulating cable is eligible for an additional seven (7) year warranty (total period of ten [10] years) provided the online warranty form (available at nuheat.com) is fully completed and registered within thirty (30) days from the date of installation.

1.7 PRE-INSTALLATION CHECKS

PLAN INSTALLATION LAYOUT

- [] It is VERY IMPORTANT to plan the installation before securing any part of the heating cable system to the roof and/or gutter system. Note the location of the controls and/or junction boxes.

DESIGN NOTES

- [] Review any design notes provided by Nuheat's Customer Care Team. Note specific installation instructions and plan which direction/sequence the cable will be installed.

CIRCUIT LENGTHS

- [] Observe the maximum circuit lengths of the cable (Appendix 1 on page 34) and do not exceed these limits during the installation. Exceeding the maximum circuit lengths will result in breaker trips which will prevent the heating cable from turning on when snow/ice is present.

ACCESSORIES

- [] Ensure you have all the necessary connection/splice kits and accessories including roof clips and downspout hangers (if applicable).

VISUALLY INSPECT HEATING CABLE

- [] Unpack and perform visual inspection of the entire heating cable for any visible damage. If the heating cable is damaged, do not begin installation. Contact Nuheat Customer Care Team at 1.800.778.WARM (9276).

INSULATION RESISTANCE AND CONTINUITY TESTS

- [] Perform insulation resistance and continuity tests. Refer to testing procedures on page 12 of this manual.

SECTION 2 INSTALLATION

2.1	GUTTERS	18
2.11	Single Run of Heating Cable	18
2.12	Double Run of Heating Cable	18
2.2	DOWNSPOUTS	19
2.21	Entering Downspout	19
2.22	Entering Downspout: Tee Splice Method	20
2.23	Exiting Downspout: Above Ground	21
2.24	Exiting Downspout: Below Ground	22
2.3	ROOFS	23
2.31	Sloped Roof	23
2.32	Heating Roof Drains	24
2.33	Flat Roof	25
2.34	Metal and Standing Seam	26
2.35	Valleys and Wall Intersections	27
2.4	POST-INSTALLATION CHECKS	28

2.1 INSTALLATION: GUTTERS

Install heating cable along gutter base to prevent ice dams and ice build-up inside the gutter system. Ice build-up can lead to icicle formations which may damage the gutter system, as well as pose a safety risk (i.e. potential falling icicles).

2.11 SINGLE RUN OF HEATING CABLE

Lay heating cable at base of gutter to create/maintain drain paths for melt water.

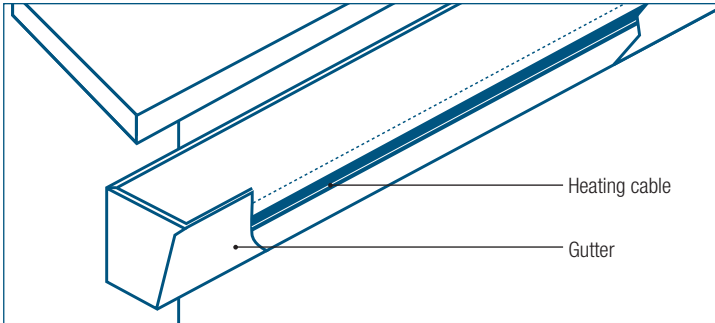

FIGURE 2.11: Single Run in Gutter

2.12 DOUBLE RUN OF HEATING CABLE

For gutters wider than 6" (150mm), use two runs of heating cable inside gutter. To ensure optimal cable spacing of 4" - 6" (100 - 150mm), secure heating cable to Nuheat downspout hangers or roof clips.

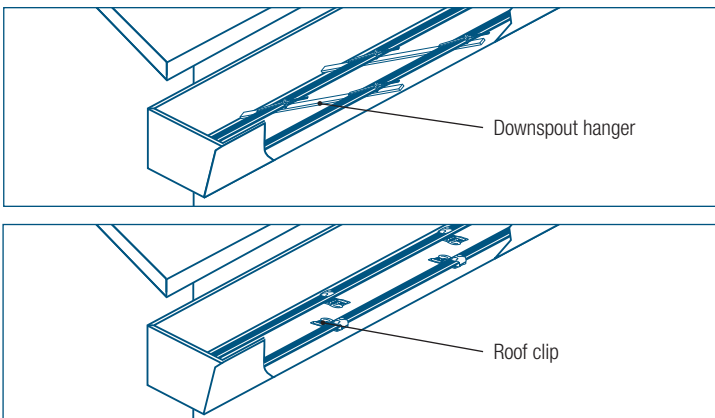

FIGURE 2.12: Double Run in Gutter

2.2 INSTALLATION: DOWNSPOUTS

Install heating cable inside all downspouts to prevent ice dams from forming within the gutter system. Heating downspouts will create drain paths for melt water to exit the gutter system and reduce the risk of ice and snow damage.

2.21 ENTERING DOWNSPOUT

Install heating cable inside the downspouts to ensure ice does not build-up and prevent melt water from exiting the gutter system.

 Use downspout hangers to protect cable from sharp edges or protrusions in the gutter.

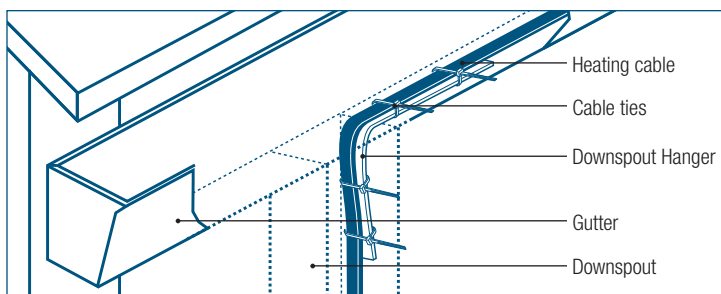

FIGURE 2.12: Heating Cable Entering Downspout

Alternatively, use loop-back method to extend heating cable into downspout. Create a loop in a single run of heating cable. Extend loop into downspout until it reaches downspout exit.

 Use downspout hangers to protect cable from sharp edges or protrusions in gutter.

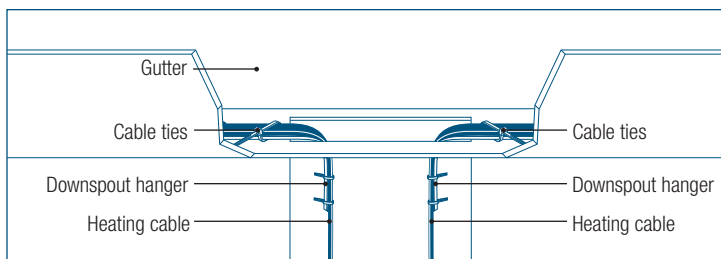

FIGURE 2.22: Loop-back Method

2.2 INSTALLATION: DOWNSPOUTS

2.2.3 ENTERING DOWNSPOUT: TEE SPLICE METHOD

If necessary, use a Nuheat splice/tee kit to create a tee-splice at entrance to downspout.

⚠ Test continuity of each cable run before installing heat shrinks.

Install connection components according to installation instructions included in connection kits. Extend a single heating cable run into downspout until it reaches downspout exit.

⚠ Use downspout hangers to protect cable from sharp edges or protrusions in the gutter.

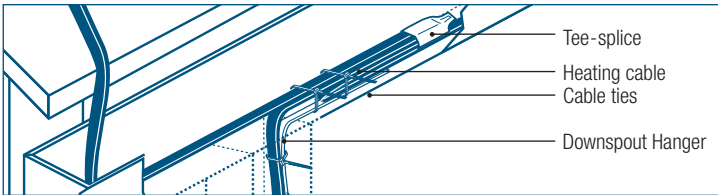

FIGURE 2.23: Tee-Splice Method

2.2.4 EXITING DOWNSPOUT: ABOVE GROUND

If a single run of heating cable is used in the downspout, terminate cable with end seal.

Create a drip loop extending 1" (25mm) past downspout exit. Secure end seal 12" (300mm) up from downspout exit.

⚠ Ensure all cable protruding past lower opening of downspout is not susceptible to damage.

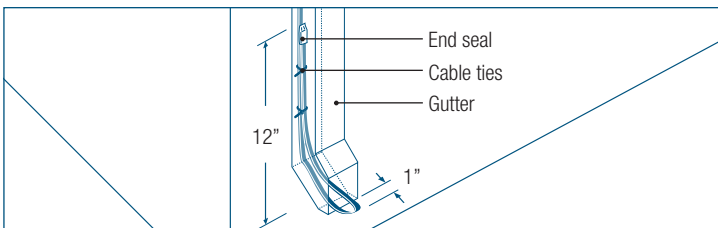



FIGURE 2.24: Exiting Downspout Above Ground

2.2 INSTALLATION: DOWNSPOUTS

2.2.5 EXITING DOWNSPOUT: BELOW GROUND

Determine the frost line depth based on the geographic region. If using the loop-back method to extend the heating cable into downspout, ensure the loop of heating cable at the bottom of the downspout extends below the frost depth.

If a single run of heating cable is extended into the downspout, create a drip loop and secure the end seal to the heating cable prior to inserting the cable into downspout.

 **Ensure all cable protruding past downspout opening is not susceptible to damage.**

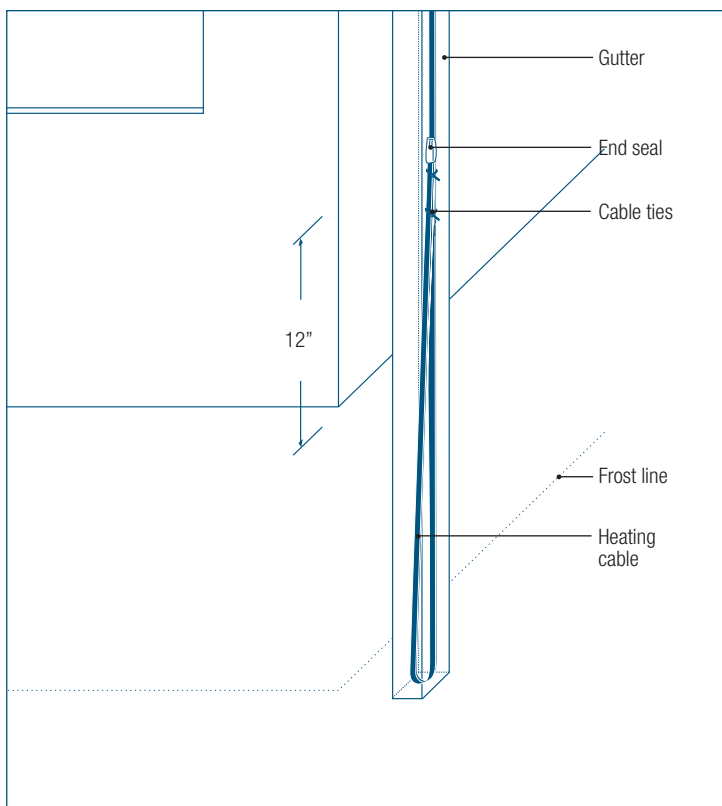

FIGURE 2.25: Exiting Downspout Below Ground

2.3 INSTALLATION: ROOF

Ice dams may form at roof edge because the section of roof above overhang is un-insulated. Install heating cable on this section of the roof to create/maintain drain paths for melt water to flow off the roof and into gutter system.

On sloped roofs, the heating cable is generally installed in a zig-zag pattern above the un-insulated overhang section of the roof.

2.31 SLOPED ROOF

Attach heating cable to roof using roof clips in a triangular pattern along roof edge. See figure 2.31.

- ⚠ Ensure top of triangle is approximately 6" (150mm) past the exterior wall.
- ⚠ Ensure distance between triangles is approximately 24" (600mm)

Extend drip loops past roof edge into gutter. If heating cable is installed along gutter base, connect drip loop to gutter run using UV-resistant cable ties. This will ensure the melt water has a continuous path from roof to gutter.

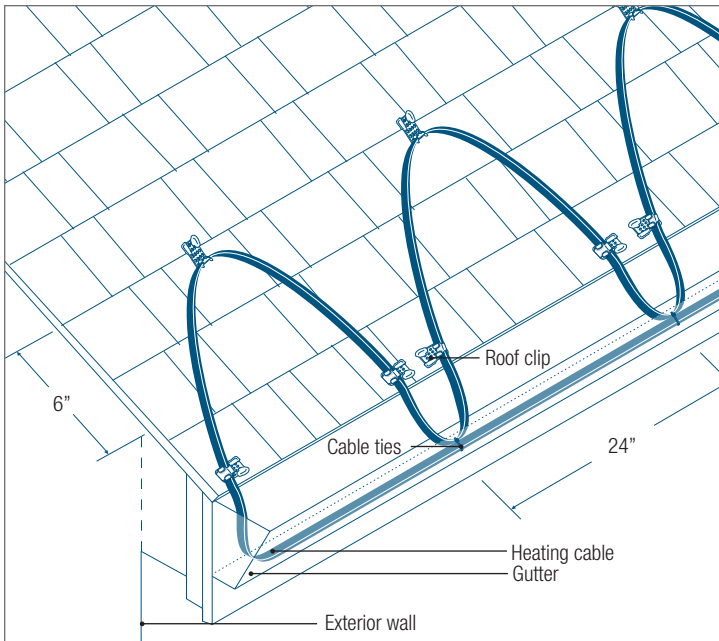

FIGURE 2.31: Sloped Roof

2.3 INSTALLATION: ROOF

2.32 HEATING ROOF DRAINS

To maintain proper roof drainage and prevent ice damage, install heating cable from roof edge to roof drain. Extend heating cable loop into roof drain, ensuring cable reaches 12" (300mm) into heated zone below roof.

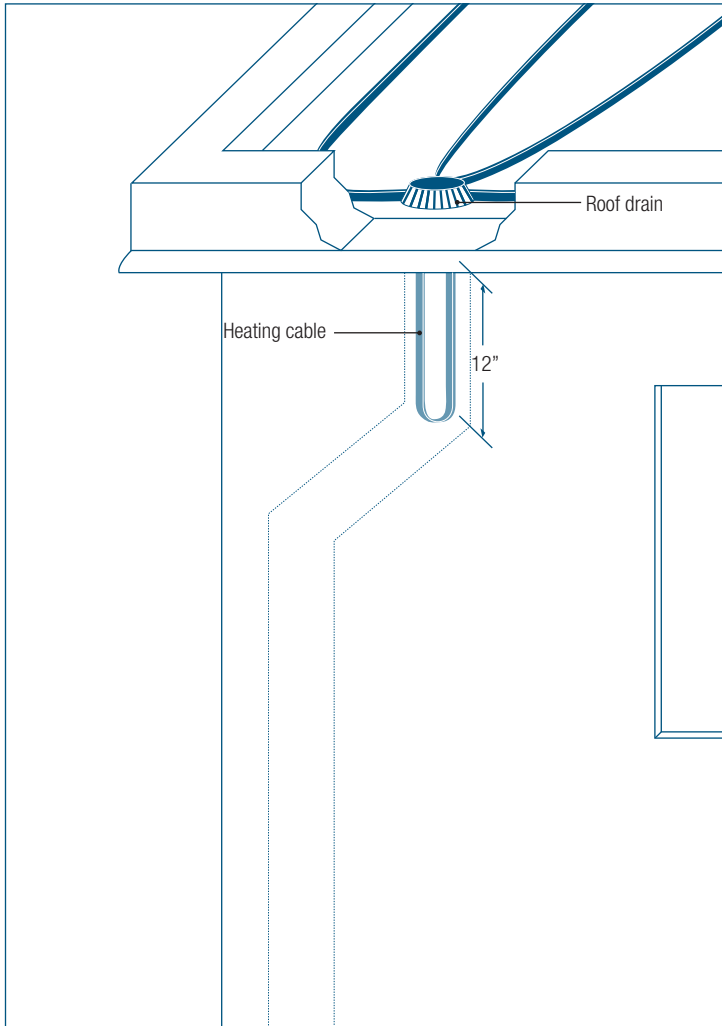

FIGURE 2.32: Roof Drains

2.3 INSTALLATION: ROOF

2.3.3 FLAT ROOF

Flat roofs are usually pitched to direct water to roof drains, downspouts or scuppers. Install heating cable around the perimeter and along the melt water path to roof drains, downspouts or scuppers. Use roof clips to secure the heating cable.

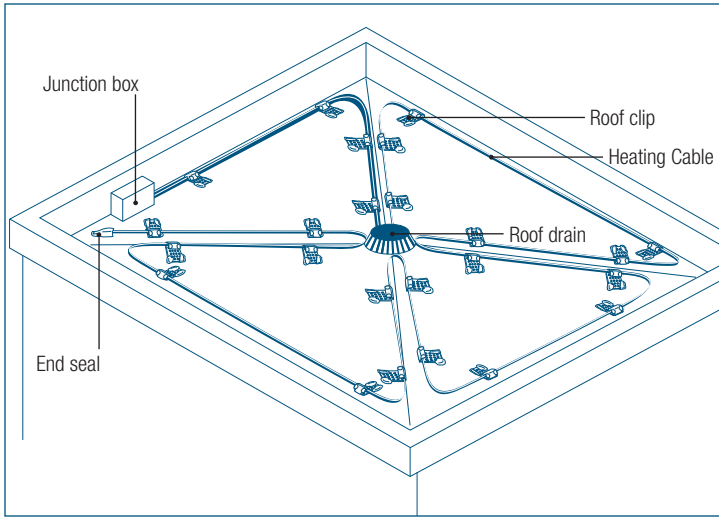

FIGURE 2.33a: Flat Roof to Drain

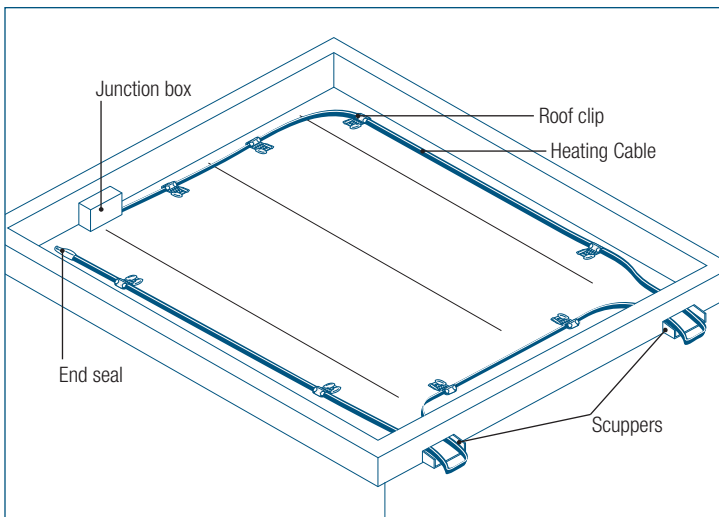

FIGURE 2.33b: Flat Roof to Scuppers

2.3 INSTALLATION: ROOF

2.3.4 METAL AND STANDING SEAM

Metal / Standing seam roofs are most common in commercial or industrial applications. Typical seam distance varies between 18" (460mm) to 24" (610mm). Using roof clips, attach heating cable to roof along seam. Run heating cable over seam and reverse direction. Extend heating cable past roof edge and into gutter. Lay heating cable horizontally along gutter base. Heating cable should be installed along every *other* seam.

⚠ Ensure top of triangle extends approximately 6" (150mm) up past exterior wall.

⚠ Distance between cable runs should not exceed 24" (610mm).

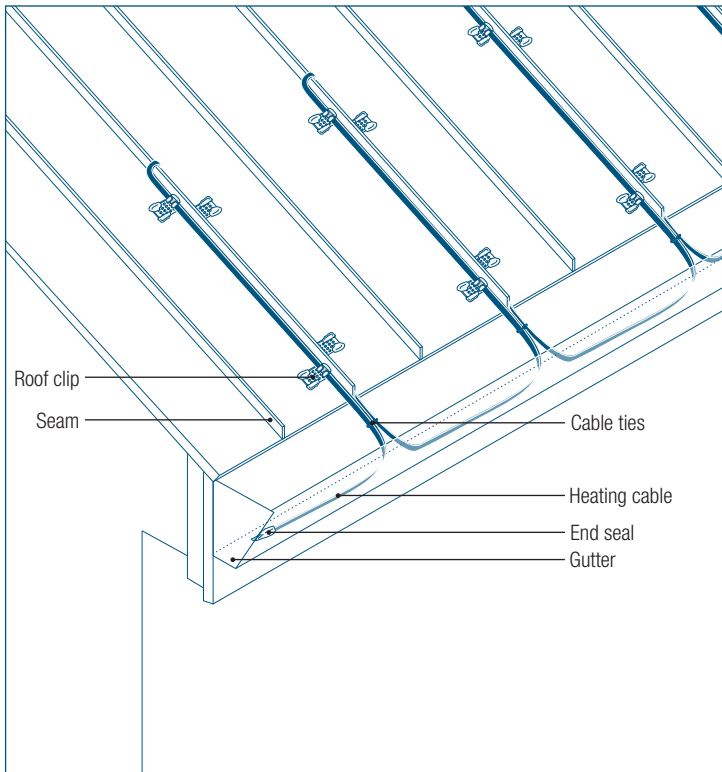

FIGURE 2.34: Metal & Standing Seam Roof

2.3 INSTALLATION: ROOF

2.35 VALLEYS AND WALL INTERSECTIONS

When sloped sections of roof meet or are intersected by a wall, the roof forms a valley or wall intersection. In both instances, run the heating cable two-thirds up the valley or wall intersection and back down to maintain drain paths.

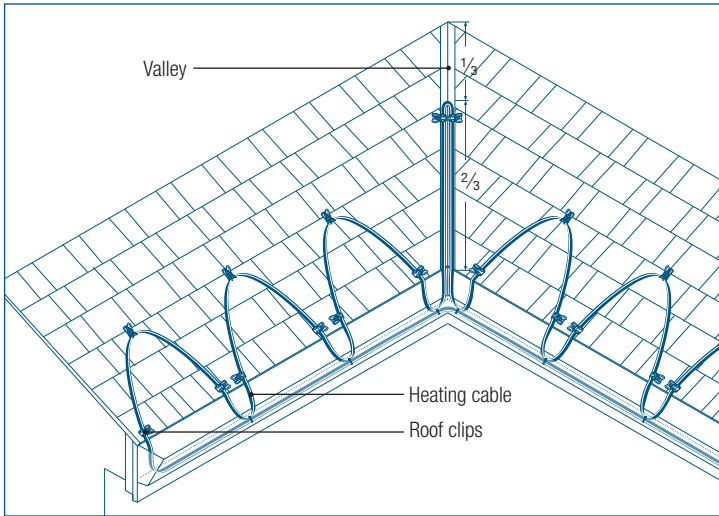

FIGURE 2.35a: Sloped Roof Valley

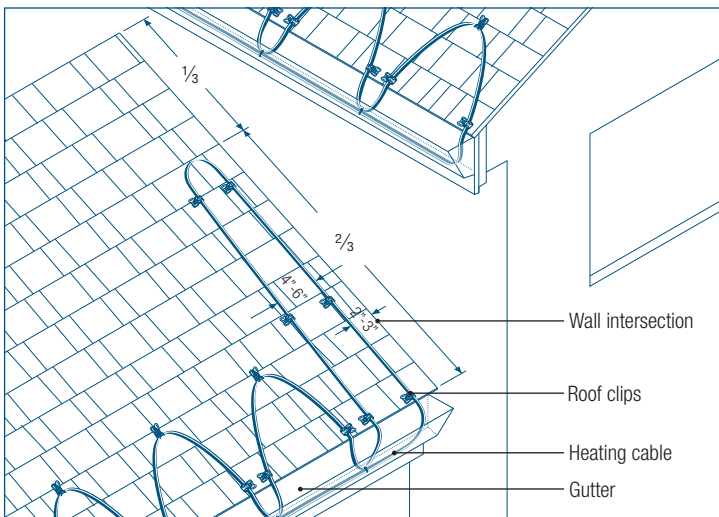

FIGURE 2.35b: Wall Intersections

2.4 POST-INSTALLATION CHECKS

DOWNSPOUT HANGERS

- [] Use downspout hangers to ensure heating cable is protected from potential mechanical damage.

INSULATION RESISTANCE TESTS

- [] Perform insulation resistance tests. Refer to testing procedures on page 12 of this manual.

CIRCUIT LENGTHS

- [] Observe the maximum circuit lengths of the cable (Appendix 1 on page 34) and do not exceed this limit during the installation. Exceeding the maximum circuit lengths will result in breaker trips which will prevent the heating cable from turning on when snow/ice is present.

SECTION 3 ELECTRIC CONNECTIONS & CONTROLS

3.1	ELECTRICAL CONNECTIONS	30
3.11	Power Connection	30
3.12	Drip Loop	30
3.2	TYPICAL WIRING DIAGRAMS	31
3.21	Single Circuit Control	31
3.22	Group Circuit Control	31
3.3	CONTROL OPTIONS	32
3.31	Automatic Snow Controllers	32
3.32	Slab Sensing Thermostat	32
3.33	Manual On/Off Control	32
3.4	REPAIRS	32
3.5	APPENDIX 1	33

3.1 ELECTRICAL CONNECTIONS

3.11 POWER CONNECTION

After heating cable and related accessories are installed, install power connection components according to installation instructions included in connection components.

Visually inspect the entire circuit and perform insulation resistance tests for each circuit before connecting heating cable to power.

3.12 DRIP LOOP

Create drip loops to prevent water from trailing into any electrical equipment, junction boxes, or controls.

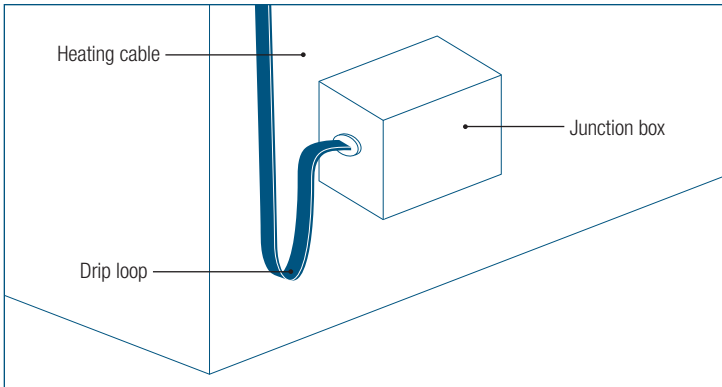
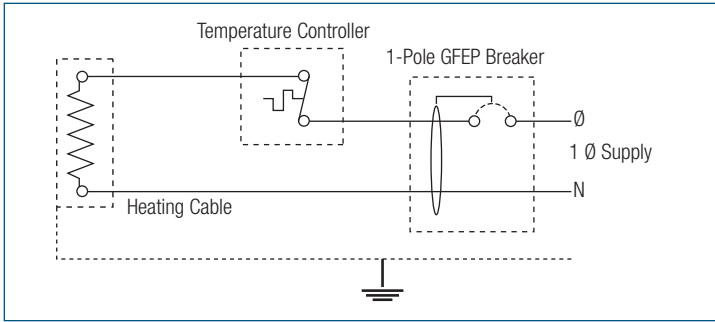

FIGURE 3.12: Drip Loop

3.2 TYPICAL WIRING DIAGRAM

3.21 SINGLE CIRCUIT CONTROL



3.22 GROUP CIRCUIT CONTROL

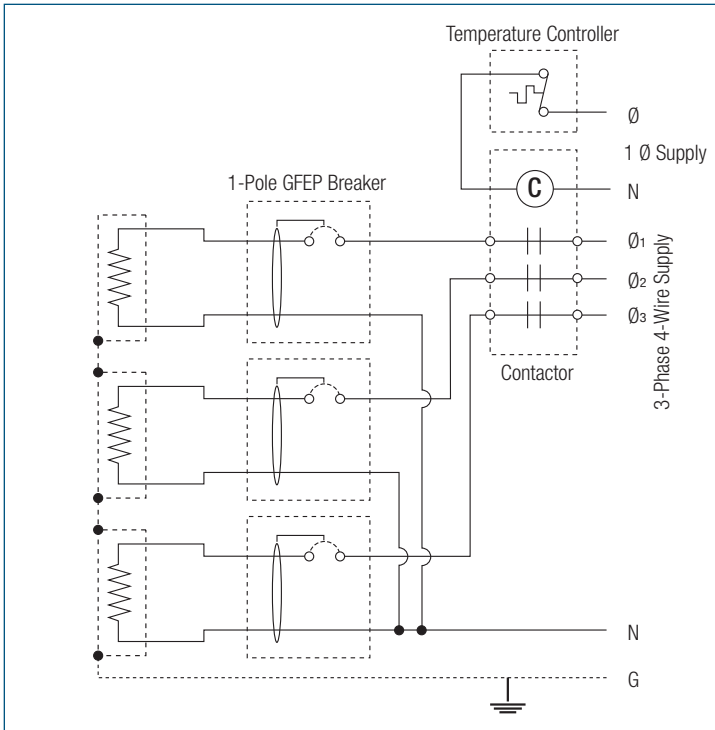

NUHEAT INDUSTRIES AND NEC REQUIRE 30mA EQUIPMENT GROUND-FAULT PROTECTION ON EACH HEATING CABLE BRANCH CIRCUIT.

3.3 CONTROL OPTIONS

There are several options available to control the Nuheat Roof and Gutter De-icing Cables. Consult the electrical contractor to determine the most suitable option. Selecting the proper control option will limit the power consumption of the de-icing system by turning on the heating cables only when it is needed.

3.31 AUTOMATIC SNOW CONTROLLER

- > Activates system when precipitation AND low temperatures are detected
- > System remains "ON" once precipitation or low temperature have ceased, allowing the surface to completely dry, preventing the formation of surface ice
- > When combined with a slab-sensing thermostat, the system will de-energize once the slab has reached the preset or user-defined temperature setpoint

3.32 AMBIENT SENSING THERMOSTAT

- > Turns on the heating cable when the ambient temperature drops below a preset or user-defined temperature (usually set at freezing point)
- > Not as energy efficient as ambient temperature may be below freezing but no precipitation/snowfall is present

3.33 MANUAL ON/OFF CONTROL

- > Low initial cost
- > Recommended only for small areas
- > Requires manual monitoring
- > Prone to be left on accidentally

Install the controls as per installation instructions that accompany control unit. Ensure controller or contactor being used is appropriate for electrical load.

3.4 REPAIRS AND MAINTENANCE

If any part of the cable becomes damaged at any time, please contact Nuheat Customer Care Team immediately at 1.800.778.WARM (9276).

Perform visual inspection, and insulation and continuity tests annually before each winter season. Ensure control system is functioning before each winter season.

3.5 APPENDIX 1

MAXIMUM CIRCUIT LENGTHS

	START UP AMBIENT		120V				240V			
	°F	°C	15A	20A	30A	40A	15A	20A	30A	40A
13FP03W	50	10	270	270	270	270	540	540	540	540
	32	0	270	270	270	270	540	540	540	540
	14	-10	245	270	270	270	495	540	540	540
	-4	-20	210	270	270	270	420	540	540	540
	-22	-30	180	245	270	270	365	490	540	540
	-40	-40	160	215	270	270	320	430	540	540
13FP05W	50	10	200	200	200	200	400	400	400	400
	32	0	190	200	200	200	385	400	400	400
	14	-10	165	200	200	200	330	400	400	400
	-4	-20	140	190	200	200	285	385	400	400
	-22	-30	125	170	200	200	255	340	400	400
	-40	-40	110	150	200	200	225	300	400	400
13FP08W	50	10	145	150	150	150	215	285	300	300
	32	0	125	150	150	150	185	250	300	300
	14	-10	110	145	150	150	165	220	300	300
	-4	-20	95	130	150	150	150	200	300	300
	-22	-30	85	115	150	150	135	180	275	300
	-40	-40	80	105	150	150	125	165	250	300
13FP10W	50	10	100	130	130	130	100	135	200	265
	32	0	90	120	130	130	90	120	180	245
	14	-10	80	110	130	130	85	110	165	225
	-4	-20	75	100	130	130	75	100	155	205
	-22	-30	70	90	130	130	70	95	145	195
	-40	-40	60	85	125	130	65	90	135	180
13RG06W	50	10	210	210	210	210	420	420	420	420
	32	0	175	210	210	210	350	420	420	420
	14	-10	140	190	210	210	290	390	420	420
	0	-18	120	160	210	210	245	325	420	420



**Freeze
Protection
Products**

PIPE • ROOF & GUTTER • SLAB

Nuheat Freeze Protection Products
toll free: 1.800.778.WARM (9276)
fax: 604.529.4404
www.nuheat.com
info@nuheat.com

Nuheat™ is the registered Trademark of Nuheat Industries Ltd.
Printed in Canada