

Nuheat

WEATHER-READY™

MINERAL INSULATED SNOW MELT CABLE

Mineral Insulated (MI) Snow Melt Cable Installation Guide

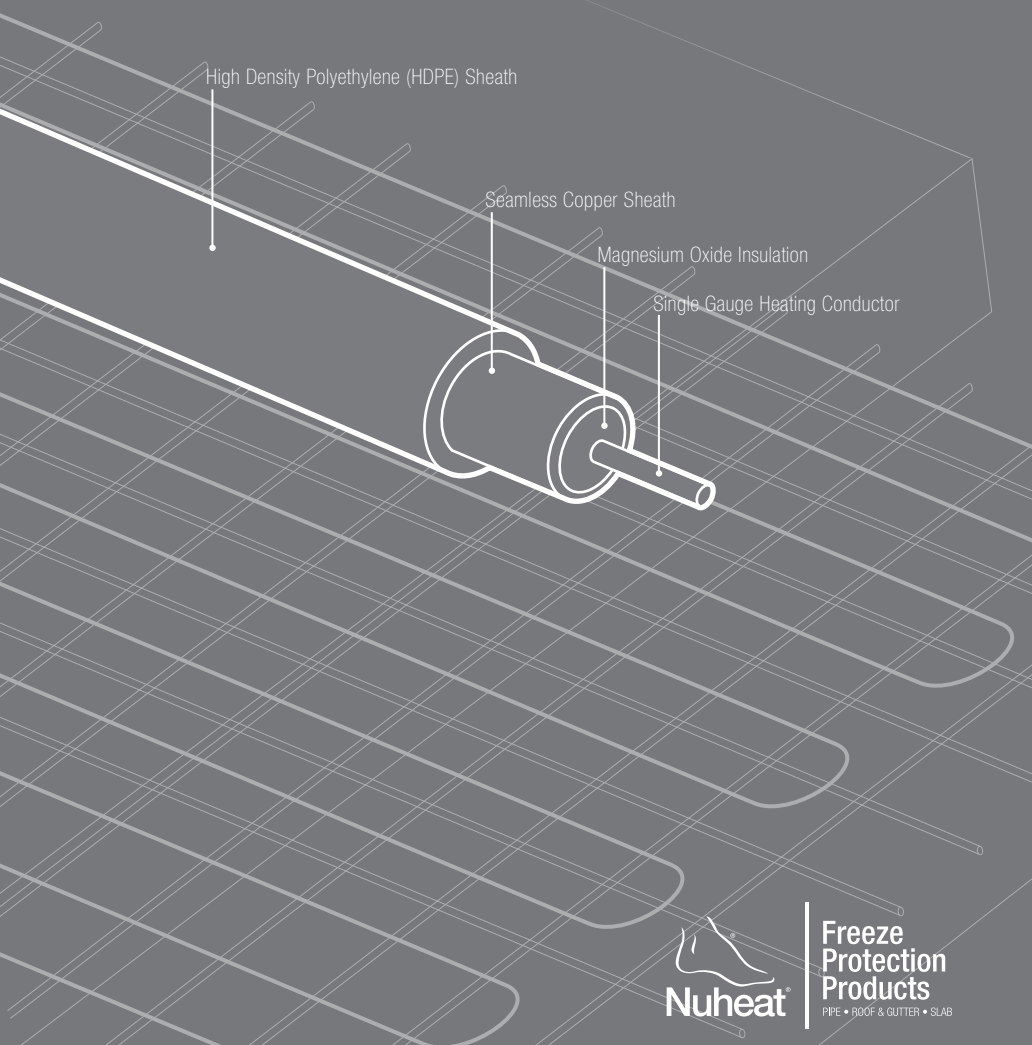

Freeze
Protection
Products
PIPE • ROOF & GUTTER • SLAB



**Freeze
Protection
Products**
PIPE • ROOF & GUTTER • SLAB

NUHEAT INDUSTRIES LIMITED

© 2014 Nuheat Industries Limited. All rights reserved.

The entire contents of this manual, including but not limited to text, images, and the selection and arrangement of information (collectively the "Materials"), are protected by copyright and other intellectual property laws under the laws of Canada and other countries.

ATTENTION:

- The installation of this heating product shall be in accordance with the manufacturer's instructions and in accordance with the Canadian Electrical Code Part 1 or the National Electrical Code (US) whichever is applicable.
- This equipment shall be installed only by qualified personnel who are familiar with the construction and operation of the apparatus and risks involved.
- Caution should be taken to guard against risk of electric shock, fire and bodily injury during the installation of this equipment.
- Indicate on the electrical panel which circuit is used for the Nuheat Freeze Protection Product.

TABLE OF CONTENTS

SECTION 1: INSTALLATION PREPARATION

1.1	Important Installation Guidelines	6
1.2	Before You Start	7
1.3	MI Snow Melt Cable Construction	8
1.4	Insulation & Resistance Tests	9
1.5	Insulation & Resistance Table	10
1.6	Warranty Information	10
1.7	Special Installation Considerations	12
1.8	Pre-Installation Checklist	17

SECTION 2: INSTALLATION

2.1	Concrete Single-Pour	20
2.2	Concrete Two-Pour	22
2.3	Asphalt on Concrete Base	24
2.4	Mastic Asphalt on Concrete Base	26
2.5	Pavers/Paving Stones on Sand Base	28
2.6	Pavers/Paving Stones on Concrete Base	30
2.7	Post-Installation Checklist	32

SECTION 3: ELECTRICAL CONNECTIONS & CONTROLS

3.1	Electrical Connections	34
3.2	Typical Wiring Diagrams	36
3.3	Control Options	41
3.4	Repairs	42

SECTION 1

INSTALLATION PREPARATION

1.1	IMPORTANT INSTALLATION GUIDELINES	6
1.2	BEFORE YOU START	7
1.21	Tools	7
1.22	Materials	7
1.3	MI CABLE CONSTRUCTION	8
1.4	INSULATION & RESISTANCE TESTS	9
1.41	Insulation Test	9
1.42	Resistance Test	9
1.5	INSULATION & RESISTANCE TABLE	10
1.6	WARRANTY INFORMATION	10
1.61	Warranty Terms	10
1.62	Extended Warranty	10
1.63	How to Claim this Warranty	11
1.64	Disclaimer	11
1.65	Warranty Coverage	11
1.7	SPECIAL INSTALLATION CONSIDERATIONS	12
1.71	Wheel Tracks	12
1.72	Stairs	13
1.73	Waterproof Membranes	13
1.74	Herringbone Pattern	14
1.75	Trench Drains	15
1.76	Concrete Joints	15
1.77	Cable Guards	16
1.78	Junction Boxes Located Below Suspended Slab	16
1.8	PRE-INSTALLATION CHECKLIST	17

1.1 IMPORTANT INSTALLATION GUIDELINES

- > Do not energize heating cable(s) before installation is complete and topping material has fully cured as per manufacturer's instructions.
- > Do not install the cables if the temperature is below -4°F / -20°C.
- > Do not cut or alter the length of the cable.
- > Do not repeatedly bend and straighten the heating portion of the cable or the cold lead tails. The minimum bend radius of the heating portion of the cable and cold lead is 6 times the outer diameter of the heating cable.
- > Do not crush or place undue pressure on the cable.
- > The heating cables must be installed in concrete, asphalt or other materials that have been designed to bear the expected load and environmental conditions over time.
- > The heating portion of the cable shall not touch, crossover, or overlap itself. Runs of heating cable must be at least 3" (75mm) apart.
- > The heating portion of the cable shall be placed at least ½" (13mm) from any combustible surface or insulating material or membrane.
- > To prevent moisture damage, make all electrical connections in above grade junction boxes where possible.
- > Materials used for the housing (i.e. junction boxes) or supports on which the cables are installed shall be grounded in accordance with CSA standard C22.1, Section 10.
- > Cable terminations should be kept dry before, during and after installation.
- > Conduct insulation and resistance tests before, during and after installation. Refer to testing procedures on page 9 of this guide.
- > All installations must be in compliance with the following electrical codes:
 - o Articles 426 and 500 of the NEC (National Electrical Code)
 - o Sections 62 and 18 of the CEC (Canadian Electrical Code)
- > The quality and preparedness of the base material must conform to generally accepted standards and specifications set by the American Society for Testing and Materials (ASTM) or Canadian Standards Association (CSA).

NUHEAT INDUSTRIES AND NEC REQUIRE 30mA EQUIPMENT GROUND-FAULT PROTECTION ON EACH HEATING CABLE BRANCH CIRCUIT.

1.2 BEFORE YOU START

The following tools/materials are required for Nuheat Weather-Ready™ MI Snow Melt Cable installation:

1.21 TOOLS

- > 500 Vdc megohmmeter
- > Multimeter
- > Adjustable wrench x 2
- > Pliers
- > Method to payout the MI heating cable(s)

1.22 MATERIALS

- > ½" (13mm) metal conduit for slab sensor / wiring (for slab-mounted sensor)
- > 1.5" - 2" (40-50mm) conduit per cable set for cold leads
 - o Only required if application requires conduit for cold lead to exit concrete slab
- > Materials to secure the Nuheat Weather-Ready™ MI Snow Melt Cable to the base layer (based on the application and installation method outlined on page 20-31):
 - o Metal mesh (6" x 6" #8 or #10 gauge metal mesh)
 - o Plastic cable ties
 - OR
 - o Pre-punched strapping
 - o Concrete screws/anchors
- > Materials needed for electrical connections
 - o Metallic or non-metallic junction boxes
 - > ½" ground bushings if non-metallic junction boxes are used
 - o ½" lock nuts (4 per MI heating cable)

1.3 MI SNOW MELT CABLE CONSTRUCTION

Nuheat Weather-Ready™ MI Snow Melt Cables' terminated cold leads are fitted with ½" NPT threaded connectors and 12" solid copper leads. The cold lead lengths vary by kit [7-foot or 15-foot long].

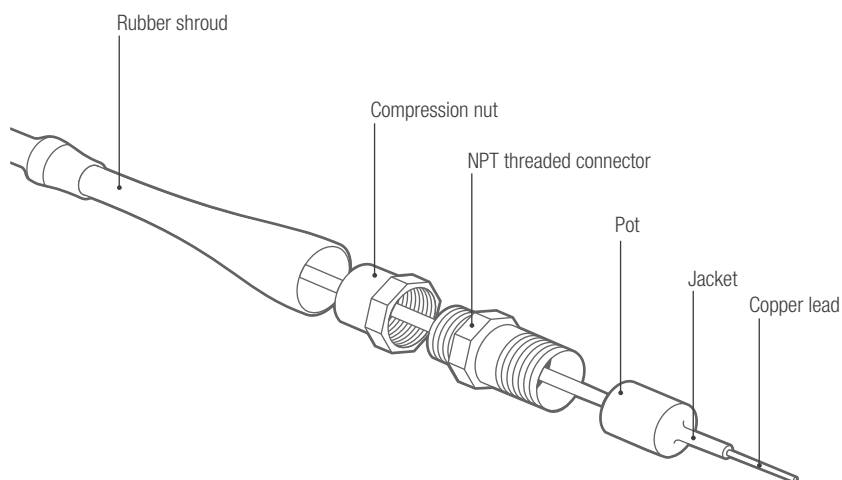

FIGURE 1.3a: MI Snow Melt Cable Cold Lead

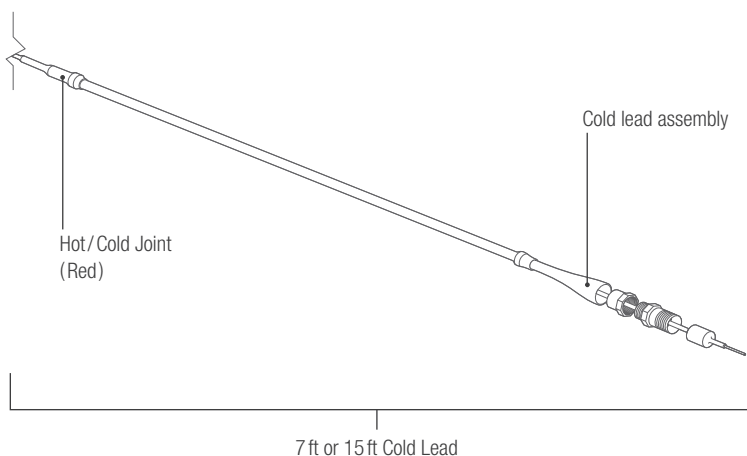

FIGURE 1.3b: MI Snow Melt Cable Hot / Cold Joint

1.4 INSULATION & RESISTANCE TESTS

Insulation and resistance tests must be performed before, during and after installation of Nuheat Weather-Ready™ MI Snow Melt Cable System. Insulation and resistance readings must be recorded in the tables in section 1.5

1.41 INSULATION TEST

1. Set megohmmeter voltage to 0 Vdc
2. Connect positive alligator clip to copper sheath at one end of heating cable
3. Connect negative alligator clip to copper conductor tail at the opposite end of heating cable
4. Turn on megohmmeter. Set voltage to 500 Vdc
5. Apply voltage for one (1) minute. Meter needle should stop moving
6. Turn off megohmmeter. Discharge conductors if necessary
7. Check resistance reading
8. Confirm resistance is greater than 10 gigohms
9. Record insulation resistance value in the table on page 10

1.42 RESISTANCE TEST

1. Calculate expected total cable resistance of heating cable
 - a. Refer to tag attached to heating cable
 - b. Multiply 'cable length' by 'resistance /ft'
2. Set multimeter to measure resistance
3. Connect positive alligator clip to copper conductor tail of heating cable
4. Connect negative alligator clip to copper conductor tail at opposite end of heating cable
5. Check continuity reading
6. Confirm resistance reading is within +/- 10% of calculated resistance value (refer to step 1)

If insulation or resistance test readings do not pass requirements at any point of the installation, halt installation immediately and contact Nuheat Customer Care at 1.800.778.WARM (9276).

1.5 INSULATION & RESISTANCE TABLE

Record heating cable insulation and resistance test in the table below and leave with the end user for warranty purposes:

	BEFORE INSTALLATION	DURING INSTALLATION	AFTER INSTALLATION
Insulation Resistance			
Continuity Resistance			

Failure to record insulation and resistance tests in the above table will void the Nuheat Weather-Ready™ MI Snow Melt Cable warranty. To submit your warranty, visit www.nuheat.com and fill out the online warranty card.

1.6 WARRANTY INFORMATION

1.61 WARRANTY TERMS

Two (2) year manufacturer's warranty from date of purchase.

1.62 EXTENDED WARRANTY

Nuheat Weather-Ready™ Mineral Insulated (MI) Snow Melt Cable is eligible for an additional eight (8) year warranty (total period of ten [10] years) provided the online warranty form (available at www.nuheat.com) is fully completed and registered within thirty (30) days from the date of installation.

1.6 WARRANTY INFORMATION

1.63 HOW TO CLAIM THIS WARRANTY

Contact the Company to provide details relating to the nature of the defect, the installation and operation of the product and the date of purchase. After examination of the information provided, the Company may advise the owner to proceed as follows:

- > Deliver or ship the product covered under the warranty to the dealer from whom it was originally purchased, the Company's local representative or, direct to Nuheat.
- > A retail sales receipt or proof of purchase should accompany the product.
- > Freight costs, if any, will be prepaid by the owner.

1.64 DISCLAIMER

This warranty gives you specific legal rights and you may also have some legal rights which may vary from state to state or, province to province. Nuheat hereby disclaims, and it is a condition of the sale, that there are no implied warranties. Some states and provinces do not allow limitations on an implied warranty so the above limitation may not apply to you.

1.65 WARRANTY COVERAGE

Nuheat's warranty obligations are limited to the terms below:

Nuheat warrants its Mineral Insulated (MI) Snow Melt Cable to be free from defects in material and workmanship. Nuheat Weather-Ready™ Mineral Insulated (MI) Snow Melt Cable must be installed and tested as per Nuheat's installation instructions for MI Snow Melt Cables. Any failures caused by structural issues, cracks, and other differential motion within the structure or on the surface/topping material are excluded. Use of non-approved components and accessories will void all warranties. The maximum liability of the Company is limited to the cost of the original product multiplied by the percentage of the warranty period remaining.

Nuheat shall in no event be liable for the cost of removal or installation, for loss or damage to, or loss of use of facilities or other property, loss of revenue, loss of use of revenue, loss of anticipated profits, or other damages or costs of any kind whatsoever, whether direct, indirect, incidental, or consequential, and in no event shall Nuheat's liability exceed an amount equal to price of the product.

1.7 SPECIAL INSTALLATION CONSIDERATIONS

1.71 WHEEL TRACKS

Snow melting only the wheel tracks of a driveway or path will reduce power consumption and electrical requirements. However, snow melting designs for wheel tracks should only be used in concrete and asphalt surface driveways.

Observe these important tips to ensure a proper installation:

- > Ensure the wheel track spacing is equal to the wheel spacing of the vehicle which will commonly use the driveway.
- > The typical width of each individual tire track is 18" and will typically use 4 runs of heating cable per track.
- > Excess heating cable can be used in the area between the tire tracks.

 **Do not overlap the heating cable.**

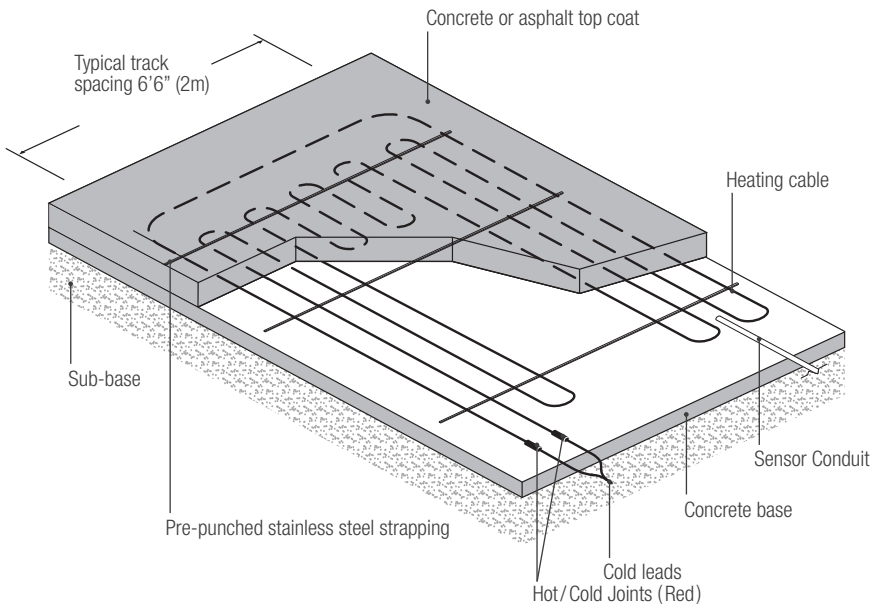

FIGURE 1.71: Heating Layout - Wheel Tracks

1.7 SPECIAL INSTALLATION CONSIDERATIONS

1.72 STAIRS

When using MI snow melt cable(s) for stair applications, special precautions need to be observed in order to ensure cable is not damaged:

- > Mark/note the locations of any rail posts to be installed. The heating cable must be at least 4" (100mm) away from all rail post mounts.
- > If heating cable(s) must go over sharp formed edges, round off sharp stair edges to prevent damage to heating cable(s).
- > The heating cable must be within 4" from the front edge of the step.

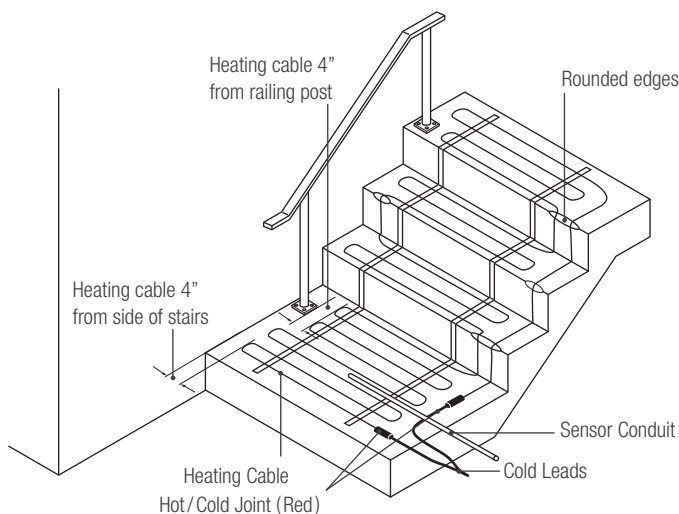

FIGURE 1.72: Heating Layout - Stairs

1.73 WATERPROOF MEMBRANES

Special consideration and certain precautions must be observed when waterproofing membranes are used within heated slabs:

- > Do not install heating cable directly on the waterproofing membrane. Heating cables must be attached to a metal mesh using plastic cable ties. Metal mesh and heating cables must be elevated a minimum of ½" (13mm) above the membrane using metal/plastic chair spacers.
- > Consult waterproofing membrane manufacturer's installation instructions for additional precautions.
- > Do not puncture the membrane.

1.7 SPECIAL INSTALLATION CONSIDERATIONS

1.74 HERRINGBONE PATTERN

Some sloped driveways have a herringbone pattern cut into the concrete surface to create drainage paths for water. Considerations for installing heating cable in herringbone pattern driveways are:

- > Install heating cable perpendicular to center herringbone cut.
- > Ensure each heating cable does not cross the center herringbone cut more than twice. The center herringbone cut is the area most susceptible to cracking, which may damage the heating cable. Use a cable guard to protect the heating cable when crossing the center herringbone cut (refer to 'Cable Guards' section on page 16).
- > Concrete thickness from the bottom of the herringbone cut to heating cable must still adhere to Nuheat recommendations for that particular installation type (refer to Section 2 of this manual).

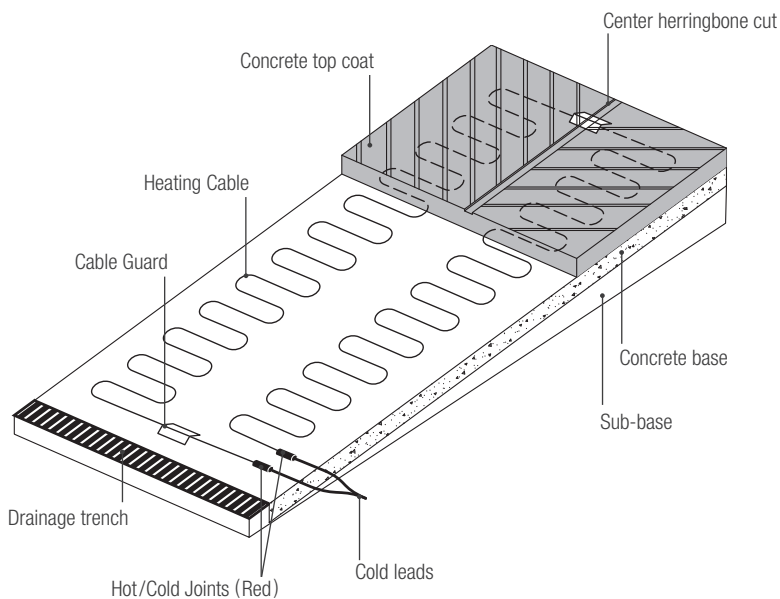

FIGURE 1.74: Heating Layout - Herringbone Pattern

1.7 SPECIAL INSTALLATION CONSIDERATIONS

1.75 TRENCH DRAINS

Heating cable should be installed at the bottom of trench drains to ensure melt water from slab will drain completely.

- > Drill two holes (2" diameter) through the concrete sidewall/form of the drain to allow the MI cable enter/exit the drain. Ensure the holes are minimum 6" apart and the holes enter at the bottom of the drain via the sidewall/form.
- > Secure two straight runs of the heating cable to the bottom of the drain using pre-punched strapping or clips. The runs should be spaced 4" apart.
- > Pour 2" of concrete/asphalt on top of the heating cable.
IMPORTANT: The cable must be embedded in concrete inside the drain.
- > Fill the 2" drill holes with hydraulic cement. Hydraulic cement expands when it sets unlike regular cement which shrinks when it sets.



Failure to heat trench drains could lead to ice build-up in the drain.

1.76 CONCRETE JOINTS

There are several types of joints typically found in concrete ramps and slabs:

Control Joints

Control joints are intended to control where the slab will crack and are normally placed at 20ft intervals. Use a cable guard to protect the heating cable when crossing control joints (refer to 'Cable Guards' section on page 16).

Construction Joints

Construction joints result when lateral concrete pours are completed at different stages during construction. Use a cable guard to protect the heating cable when crossing construction joints (refer to 'Cable Guards' section on page 16).

Expansion Joints

Expansion joints result when a concrete structure is built abutting another concrete structure. The two structures are not connected using rebar, therefore movement can/will occur between the structures. **DO NOT** cross expansion joints with the heating portion of the cable. The **cold lead portion** of the MI snow melt cable may cross expansion joints as long as the cold lead is housed inside a watertight, sealed, flexible non-metallic conduit.

1.7 SPECIAL INSTALLATION CONSIDERATIONS

1.7.7 CABLE GUARDS

Cable guards mechanically protect the heating cable from damage due to concrete movement across control or construction joints. Silicone rubber must be used between heating cable and cable guard to help dissipate heat.

To create the cable guard(s):

1. Bend a 2" x 10" piece of 1/8" (3mm) steel in half, lengthwise.
2. Cut notches in the steel cable guard for plastic cable ties.
3. Secure heating cable to formed cable guard using plastic cable ties.
4. **IMPORTANT:** Fill cable guard void with silicone rubber. Ensure heating cable inside cable guard is completely encased in silicone rubber.
5. Place the cable guard over the control / construction joint.

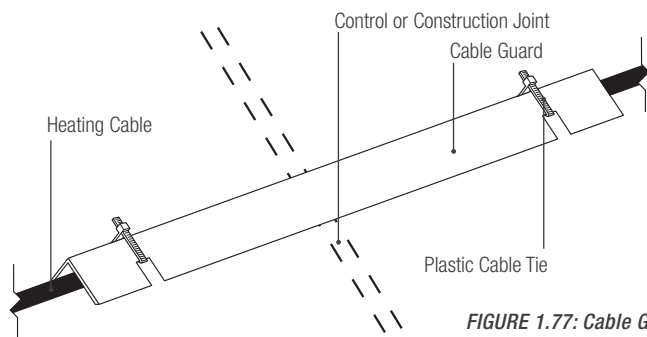

FIGURE 1.77: Cable Guard

1.7.8 JUNCTION BOXES LOCATED BELOW SUSPENDED SLAB

Certain applications may require a junction box to be located below the slab. Follow these important instructions to ensure proper installation when installing the junction box below the slab:

- > Drill core holes through the structural slab as needed to pass the cold leads through to the junction box.
- > Mount the junction box using 1/2" (13mm) standoffs or spacers to prevent condensation from forming on the junction box. The junction box should be mounted on the high side of the slope.
- > Create drip loops with the cold lead to prevent water from trailing into the junction box.
- > Fill core holes with hydraulic cement to limit water penetration.

1.8 PRE-INSTALLATION CHECKLIST

PLAN INSTALLATION LAYOUT

- [] It is VERY IMPORTANT to plan the entire MI system installation before securing any part of the heating cable system to the slab. Nuheat Weather-Ready™ MI Snow Melt Cable is a single-conductor cable which requires the end of the heating cable to return back to the starting point / junction box. Therefore, it is important to note the location of the junction box and plan which direction the cable runs will be installed.

VISUALLY INSPECT HEATING CABLE

- [] Unpack and perform visual inspection of the entire heating cable for any visible damage. If the heating cable is damaged, do not begin installation. Contact Nuheat Customer Care Team at 1.800.778.WARM (9276).

INSULATION & RESISTANCE TESTS

- [] Perform insulation and resistance tests and compare with readings on cable tag. Refer to testing procedures on page 9 of this manual.

SECTION 2 INSTALLATION

2.1	CONCRETE SINGLE-POUR	20
2.11	Securing the Cold Leads and Heating Cable	20
2.12	Installing a Slab-Sensing Thermostat and Sensor	20
2.13	Covering the Heating Cable	21
2.2	CONCRETE TWO-POUR	22
2.21	Securing the Cold Leads and Heating Cable	22
2.22	Installing a Slab-Sensing Thermostat and Sensor	23
2.23	Covering the Heating Cable	23
2.3	ASPHALT ON CONCRETE	24
2.31	Securing the Cold Leads and Heating Cable	24
2.32	Installing a Slab-Sensing Thermostat and Sensor	25
2.33	Covering the Heating Cable	25
2.4	MASTIC ASPHALT ON CONCRETE	26
2.41	Securing the Cold Leads and Heating Cable	26
2.42	Installing a Slab-Sensing Thermostat and Sensor	27
2.43	Covering the Heating Cable	27
2.5	PAVERS ON SAND BASE	28
2.51	Securing the Cold Leads and Heating Cable	28
2.52	Installing a Slab-Sensing Thermostat and Sensor	29
2.53	Covering the Heating Cable	29
2.6	PAVERS ON CONCRETE BASE	30
2.61	Securing the Cold Leads and Heating Cable	30
2.62	Installing a Slab-Sensing Thermostat and Sensor	31
2.63	Covering the Heating Cable	31
2.7	POST-INSTALLATION CHECKLIST	32

2.1 INSTALLATION: CONCRETE SINGLE-POUR

2.1.1 SECURING THE COLD LEADS AND HEATING CABLE

1. Perform 'Pre-Installation Checklist'. Refer to page 17.
2. Install 6" x 6" #8 or #10 gauge metal mesh. If applicable, secure metal mesh to reinforcing rebar using plastic cable ties.

⚠ **Heating cable must be 2" – 3" (50mm – 75mm) below final surface level. If necessary, use metal/plastic chair spacers to elevate metal mesh to appropriate height.**

3. Unreel a cold lead. Using plastic cable ties, secure hot/cold joint to metal mesh at least 6" (150mm) in from the edge of the slab.

⚠ **All cold leads must reach the electrical connection junction box.**

4. Unreel heating cable in a serpentine pattern over metal mesh, spacing the runs as per installation plan. Secure heating cable to metal mesh with plastic cable ties.

⚠ **Proper heating cable spacing will ensure required watt density.**

5. Space the second hot / cold joint at least 4" (100mm) away from first hot / cold joint and 6" (150mm) in from the edge of the slab. See Figure 2.11.

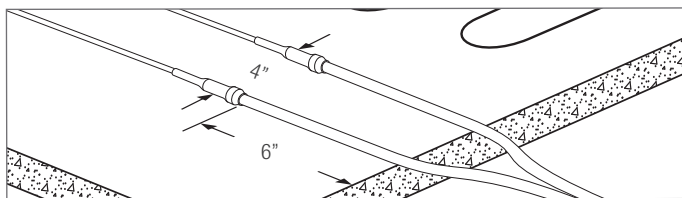

FIGURE 2.11: Cold Lead Positioning

Use plastic cable ties to secure second hot / cold joint to metal mesh or rebar.

2.1.2 INSTALLING A SLAB-SENSING THERMOSTAT OR SENSOR (IF APPLICABLE)

1. Install ½" (13mm) metal conduit between two runs of heating cable. Each slab sensor or slab sensing probe requires a separate metal conduit. Both probe and sensor must be in an area exposed to regular precipitation and/or traffic. Avoid placing probe or sensor near external heat sources (i.e. a fan).

⚠ **Seal or cap buried conduit ends to ensure a watertight seal.**

2.1 INSTALLATION: CONCRETE SINGLE-POUR

2.13 COVERING THE HEATING CABLE

1. Perform 'Post-Installation Checklist'. Refer to page 32.
2. Prepare and pour the concrete as per manufacturer's instructions.

 **Heating cable must be 2"–3" (50mm–75mm) below final grade.**

3. Perform insulation and resistance tests and compare with readings on cable tag. Record test readings on page 10.
4. Allow the concrete to cure as per manufacturer's instructions.
5. Make final heating cable electrical connections. Refer to page 34.
6. Install the thermostat and /or control unit per manufacturer's instructions.

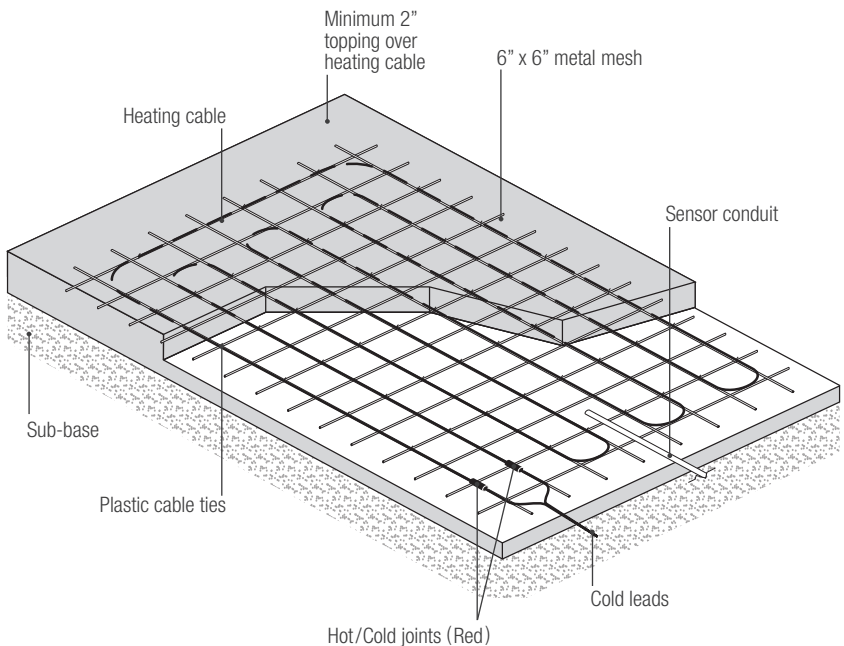

FIGURE 2.13: Concrete Single-Pour

2.2 INSTALLATION: CONCRETE TWO-POUR

2.21 SECURING THE COLD LEADS AND HEATING CABLE

1. Perform 'Pre-Installation Checklist'. Refer to page 17.
2. Using concrete anchors/screws, secure pre-punched strapping to concrete base layer according to your installation plan.

⚠ **Additional pre-punched strapping may be required at 3'-4' (ft) intervals to properly secure heating cable during installation.**

3. Unreel a cold lead. Secure the hot/cold joint to concrete base layer by bending back the pre-punched strapping tabs. Space the hot/cold joint at least 6" (150mm) in from the edge of the slab. See Figure 2.21a.

⚠ **All cold leads must reach the electrical connection junction box.**

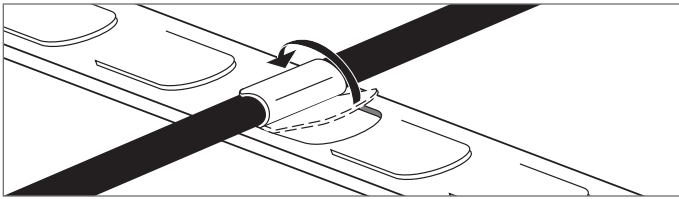

FIGURE 2.21a: Pre-Punched Stainless Steel Strapping

4. Unreel heating cable in a serpentine pattern over concrete base layer, spacing the runs as per installation plan. Using pre-punched strapping, secure heating cable to concrete base layer. See Figure 2.21a.

⚠ **Proper heating cable spacing will ensure required watt density.**

5. Space the second hot/cold joint at least 4" (100mm) away from first hot/cold joint and 6" (150mm) in from the edge of the slab. See Figure 2.21b.

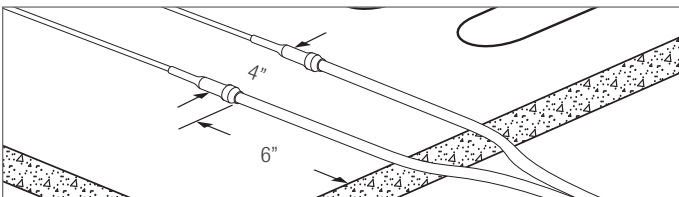

FIGURE 2.21b: Cold Lead Positioning

Use pre-punched strapping to secure second hot/cold joint to concrete base.

2.2 INSTALLATION: CONCRETE TWO POUR

2.2.2 INSTALLING A SLAB-SENSING THERMOSTAT OR SENSOR (IF APPLICABLE)

1. Install ½" (13mm) metal conduit between two runs of heating cable. Each slab sensor or slab sensing probe requires a separate metal conduit. Both probe and sensor must be in an area exposed to regular precipitation and/or traffic. Avoid placing probe or sensor near external heat sources (i.e. a fan).

 Seal or cap buried conduit ends with silicone to ensure watertight seal.

2.2.3 COVERING THE HEATING CABLE

1. Perform 'Post-Installation Checklist'. Refer to page 32.
2. Prepare and pour the concrete as per manufacturer's instructions.

 Heating cable must be 2"–3" (50mm–75mm) below final grade.

3. Perform insulation and resistance tests and compare with readings on cable tag. Record test readings on page 10.
4. Allow the concrete to cure as per manufacturer's instructions.
5. Make final heating cable electrical connections. Refer to page 34.
6. Install the thermostat and/or control unit per manufacturer's instructions.

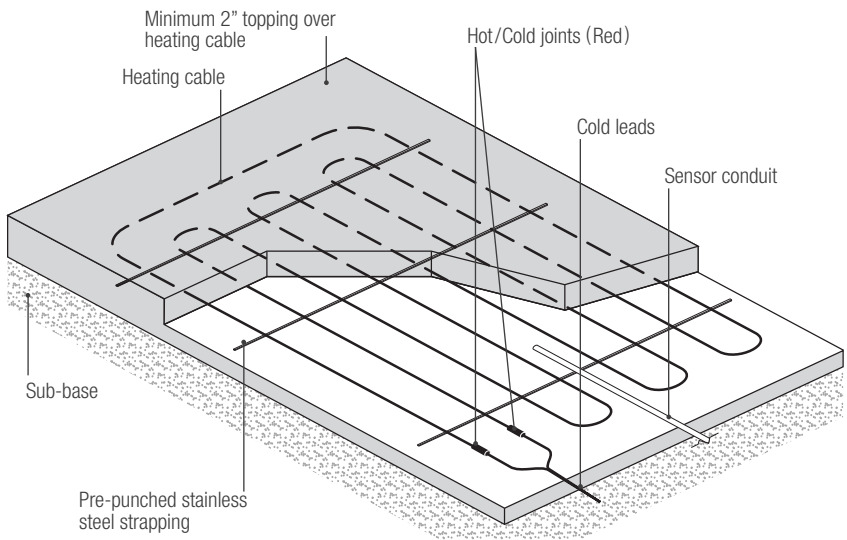

FIGURE 2.23: Concrete Two-Pour

2.3 INSTALLATION: ASPHALT ON CONCRETE

2.31 SECURING THE COLD LEADS AND HEATING CABLE

1. Perform 'Pre-Installation Checklist'. Refer to page 17.
2. Apply minimum 1" (25mm) asphalt layer over concrete base. Allow to set.
3. Using concrete anchors/screws, secure pre-punched strapping to asphalt base layer according to your installation plan.

! Additional pre-punched strapping may be required at 3' - 4' (ft) intervals to properly secure heating cable during installation.

4. Unreel a cold lead. Secure the hot/cold joint to asphalt base layer by bending back the pre-punched strapping tabs. Space the hot/cold joint at least 6" (150mm) in from the edge of the slab. See Figure 2.31a.

! All cold leads must reach the electrical connection junction box.

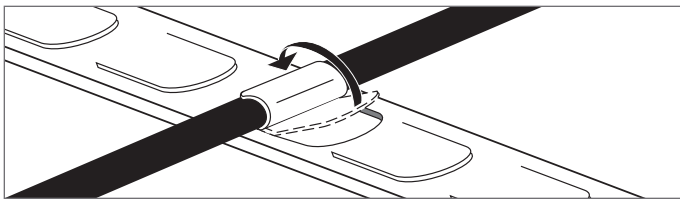

FIGURE 2.31a: Pre-Punched Stainless Steel Strapping

5. Unreel heating cable in a serpentine pattern over asphalt base layer, spacing the runs as per installation plan. Using pre-punched strapping, secure heating cable to asphalt base layer. See Figure 2.31a.

! Heating cable must be 12" (300mm) from exposed edge of the slab.

6. Space the second hot/cold joint at least 4" (100mm) away from first hot/cold joint and 6" (150mm) in from the edge of the slab. See Figure 2.31b.

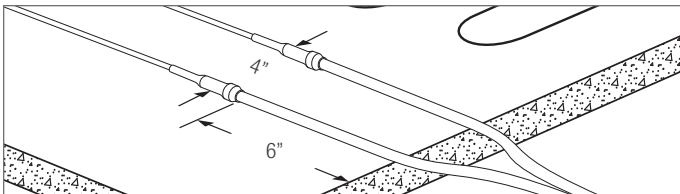

FIGURE 2.31b: Cold Lead Positioning

Use pre-punched strapping to secure second hot/cold joint to asphalt base.

2.3 INSTALLATION: ASPHALT ON CONCRETE

2.3.2 INSTALLING A SLAB-SENSING THERMOSTAT OR SENSOR (IF APPLICABLE)

1. Install ½" (13mm) metal conduit between two runs of heating cable. Each slab sensor or slab sensing probe requires a separate metal conduit. Both probe and sensor must be in an area exposed to regular precipitation and/or traffic. Avoid placing probe or sensor near external heat sources (i.e. a fan).

⚠ Seal or cap buried conduit ends with silicone to ensure watertight seal.

2.3.3 COVERING THE HEATING CABLE

1. Perform 'Post-Installation Checklist'. Refer to page 32.
2. Manually place minimum 1½" (40mm) thick bedding coat of HL3A asphalt.
3. Compact to approximately 1" (25mm) thick using a 1.5 ton roller or hand tamper. Add more asphalt if necessary.
4. Apply a minimum 1½" (40mm) thick traffic coat of HL3 asphalt.
5. Compact to approximately 1" (25mm) thick. Add more asphalt if necessary.
6. Perform insulation and resistance tests and compare with readings on cable tag. Record test readings on page 10.
7. Allow the asphalt to cure as per manufacturer's instructions.
8. Make the final heating cable electrical connections. Refer to page 34.
9. Install the thermostat and/or control unit per manufacturer's instructions.

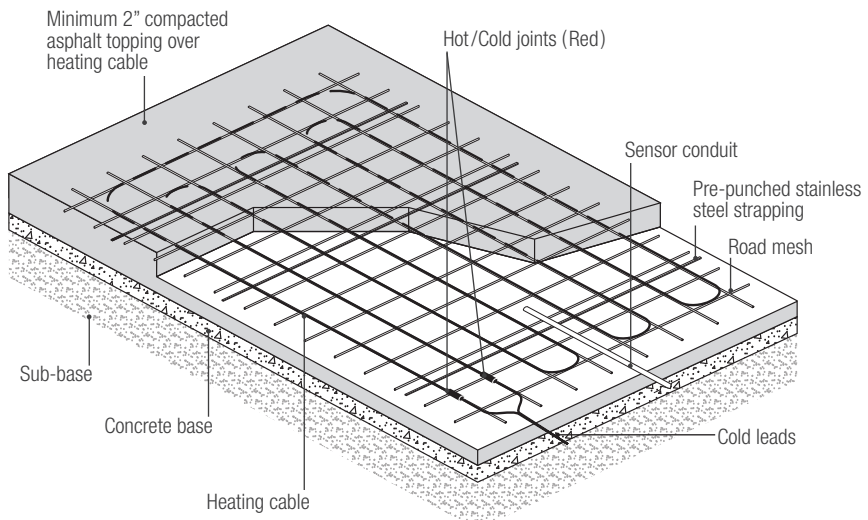

FIGURE 2.33: Asphalt on Concrete

2.4 INSTALLATION: MASTIC ON CONCRETE

2.41 SECURING THE COLD LEADS AND HEATING CABLE

1. Perform 'Pre-Installation Checklist'. Refer to page 17.
2. Apply minimum 0.5" (13mm) of mastic asphalt over concrete base. Allow to set.
3. Using concrete anchors/screws, secure pre-punched strapping to mastic asphalt base layer according to your installation plan.

! Additional pre-punched strapping may be required at 3'-4' (ft) intervals to properly secure heating cable during installation.

4. Unreel a cold lead. Secure the hot/cold joint to mastic asphalt base layer by bending back the pre-punched strapping tabs. Space the hot/cold joint at least 6" (150mm) in from the edge of the slab. See Figure 2.41a.

! All cold leads must reach the electrical connection junction box.

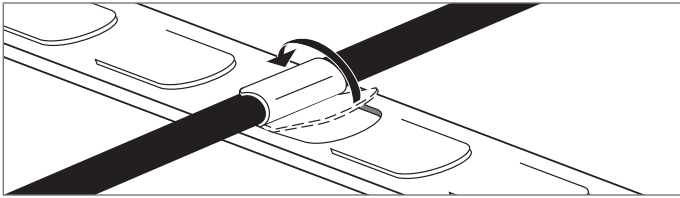

FIGURE 2.41a: Pre-Punched Stainless Steel Strapping

5. Unreel heating cable in a serpentine pattern over mastic asphalt base layer, spacing the runs as per installation plan. Using pre-punched strapping, secure heating cable to mastic asphalt base layer. See Figure 2.41a.

! Heating cable must be 12" (300mm) from exposed edge of the slab.

6. Space the second hot/cold joint at least 4" (100mm) away from first hot/cold joint and 6" (150mm) in from the edge of the slab. See Figure 2.41b.

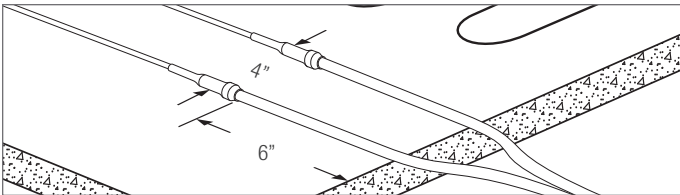

FIGURE 2.41b: Cold Lead Positioning

Use pre-punched strapping to secure second hot/cold joint to mastic base.

2.4 INSTALLATION: MASTIC ON CONCRETE

2.4.2 INSTALLING A SLAB-SENSING THERMOSTAT OR SENSOR (IF APPLICABLE)

1. Install ½" (13mm) metal conduit between two runs of heating cable. Each slab sensor or slab sensing probe requires a separate metal conduit. Both probe and sensor must be in an area exposed to regular precipitation and/or traffic. Avoid placing probe or sensor near external heat sources (i.e. a fan).

⚠ Seal or cap buried conduit ends with silicone to ensure watertight seal.

2.4.3 COVERING THE HEATING CABLE

1. Place 6" x 6" #8 or #10 gauge metal mesh over the heating cable to prevent the cable from rising.
2. Perform 'Post-Installation Checklist'. Refer to page 32.
3. Apply a ½" (13mm) thick bedding coat of mastic asphalt. Allow to set.
4. Apply a second ½" (13mm) thick traffic coat of mastic asphalt.
5. Perform insulation and resistance tests and compare with readings on cable tag. Record test readings on page 10.
6. Allow the mastic asphalt to cure as per manufacturer's instructions.
7. Make final heating cable electrical connections. Refer to page 34.
8. Install the thermostat and/or control unit per installation instructions.

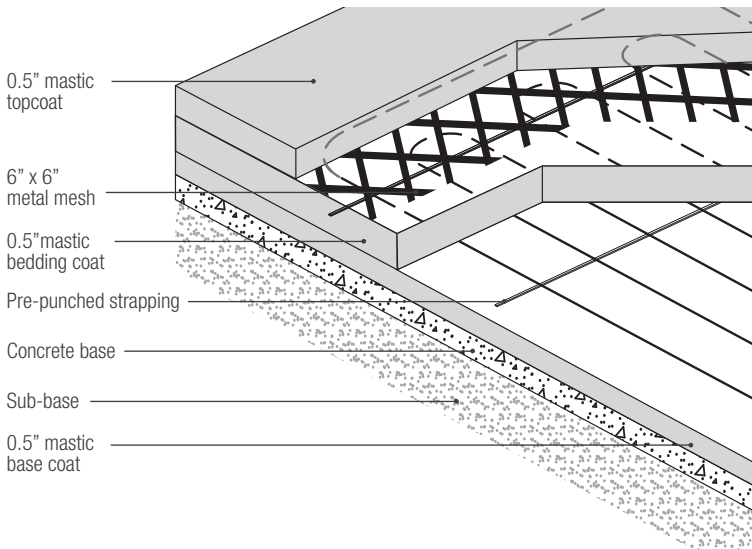

FIGURE 2.43: Mastic Asphalt on Concrete

2.5 INSTALLATION: PAVERS ON SAND BASE

2.51 SECURING THE COLD LEADS AND HEATING CABLE

1. Perform 'Pre-Installation Checklist'. Refer to page 17.
2. Lay landscape fabric over the base. This will prevent melt water from deteriorating the layer of screening material that will be laid on top.
3. Evenly spread a 1½" (40mm) layer of sand/limestone screening over landscape fabric.

! Do not use sand on sloped areas.

4. Compact and level the sand/limestone screening layer to 1" (25mm) using hand tamper or plate compactor. Add more sand/limestone if necessary.
5. Lay 6" x 6" #8 or #10 gauge metal mesh over the compacted sand/limestone screening layer. If multiple pieces of metal mesh are used, secure all grids together using plastic cable ties.

! Do not secure the metal mesh to the ground.

6. Unreel a cold lead. Using plastic cable ties, secure the hot/cold joint to mesh at least 6" (150mm) in from the edge of the slab.

! All cold leads must reach the electrical connection junction box.

7. Unreel heating cable in a serpentine pattern over metal mesh, spacing the runs as per installation plan. Secure heating cable to metal mesh with plastic cable ties.

! Proper heating cable spacing will ensure required watt density.

8. Space second hot/cold joint at least 4" (100mm) away from first hot/cold joint and 6" (150mm) in from the edge of the slab. See Figure 2.51.

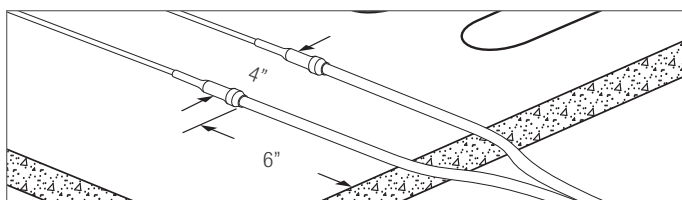

FIGURE 2.51: Cold Lead Positioning

Use plastic cable ties to secure second hot/cold joint to metal mesh.

2.5 INSTALLATION: PAVERS ON SAND BASE

2.5.2 INSTALLING A SLAB-SENSING THERMOSTAT OR SENSOR (IF APPLICABLE)

1. Install ½" (13mm) metal conduit between two runs of heating cable. Each slab sensor or slab sensing probe requires a separate metal conduit. Both probe and sensor must be in an area exposed to regular precipitation and/or traffic. Avoid placing probe or sensor near external heat sources (i.e. a fan).

 **Seal or cap buried conduit ends with silicone to ensure watertight seal.**

2.5.3 COVERING THE HEATING CABLE

1. Perform 'Post-Installation Checklist'. Refer to page 32.
2. Apply a second 1½" (40mm) thick layer of sand/limestone screening.
3. Compact and level the sand/limestone screening layer to 1" (25mm) using hand tamper or plate compactor. Add more sand/limestone if necessary.

 **Do not use sand on sloped areas.**

4. Perform insulation and resistance tests and compare with readings on cable tag. Record test readings on page 10.
5. Install pavers/paving stones and tamp per manufacturer's instructions.
6. Fill in grooves between the pavers/paving stones with polymeric sand.
7. Make final heating cable electrical connections. Refer to page 34.
8. Install the thermostat and/or control unit per installation instructions.

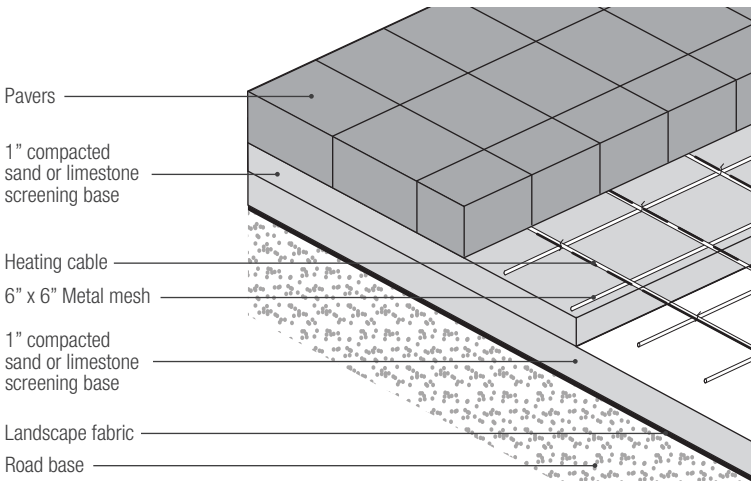

FIGURE 2.53: Pavers / Paving Stones on Sand Base

2.6 INSTALLATION: PAVERS ON CONCRETE

2.61 SECURING THE COLD LEADS AND HEATING CABLE

1. Perform 'Pre-Installation Checklist'. Refer to page 17.
2. Using concrete anchors/screws, secure pre-punched strapping to concrete base layer according to your installation plan.

⚠ **Additional pre-punched strapping may be required at 3-4 ft intervals to properly secure heating cable during installation.**

3. Unreel a cold lead. Secure hot/cold joint to concrete base layer by bending back the pre-punched strapping tabs. Space hot/cold joint at least 6" (150mm) in from the edge of the slab. See Figure 2.61a.

⚠ **All cold leads must reach the electrical connection junction box.**

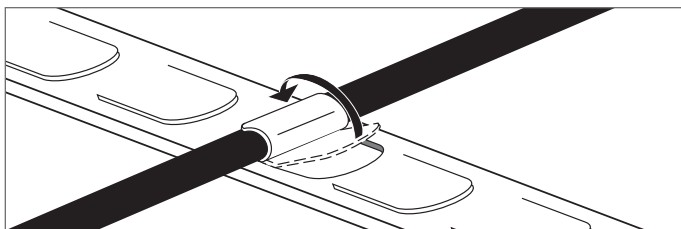

FIGURE 2.61a: Pre-Punched Stainless Steel Strapping

4. Unreel heating cable in a serpentine pattern over concrete base layer, spacing the runs as per installation plan. Using pre-punched strapping, secure heating cable to concrete base layer. See Figure 2.61a.

⚠ **Proper heating cable spacing will ensure required watt density.**

5. Space second hot/cold joint at least 4" (100mm) away from first hot/cold joint and 6" (150mm) in from the edge of the slab. See Figure 2.61b.

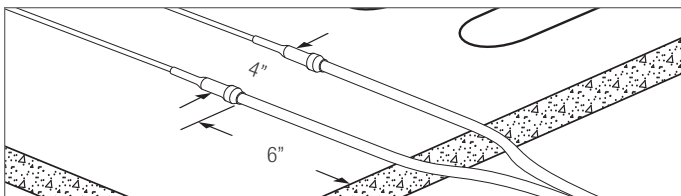

FIGURE 2.61b: Cold Lead Positioning

Use pre-punched strapping to secure second hot/cold joint to concrete base.

2.6 INSTALLATION: PAVERS ON CONCRETE

2.6.2 INSTALLING A SLAB-SENSING THERMOSTAT OR SENSOR (IF APPLICABLE)

1. Install ½" (13mm) metal conduit between two runs of heating cable. Each slab sensor or slab sensing probe requires a separate metal conduit. Both probe and sensor must be in an area exposed to regular precipitation and/or traffic. Avoid placing probe or sensor near external heat sources (i.e. a fan).

⚠ **Seal or cap buried conduit ends with silicone to ensure watertight seal.**

2.6.3 COVERING THE HEATING CABLE

1. Perform 'Post-Installation Checklist'. Refer to page 32.
2. Apply a second 1½" (40mm) thick layer of sand/limestone screening.
3. Compact and level the sand/limestone screening layer to 1" (25mm) using hand tamper or plate compactor. Add more sand/limestone if necessary.

⚠ **Do not use sand on sloped areas.**

4. Perform insulation and resistance tests and compare with readings on cable tag. Record test readings on page 10.
5. Install pavers/paving stones and tamp per manufacturer's instructions.
6. Fill in grooves between the pavers/paving stones with polymeric sand.
7. Make final heating cable electrical connections. Refer to page 34.
8. Install the thermostat and/or control unit per installation instructions.

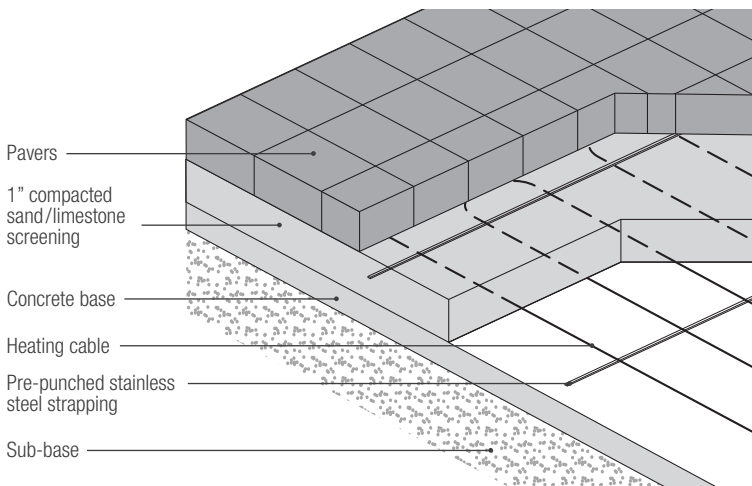

FIGURE 2.6.3: Pavers / Paving Stones on Concrete

2.7 POST-INSTALLATION CHECKLIST

VERIFY SPACING & DEPTH

- Ensure the depth and spacing of the Nuheat Weather-Ready™ MI Snow Melt Cable adheres to the prescribed installation instructions for the pertaining application.

CABLE GUARDS

- Ensure that the heating cable does not cross expansion joints. Refer to the Cable Guard section on page 16 if the cable crosses control joints or construction joints.

INSULATION & RESISTANCE TESTS

- Perform insulation and resistance tests and compare with readings on cable tag. Refer to testing procedures on page 9 of this manual.

SECTION 3 ELECTRIC CONNECTIONS & CONTROLS

3.1	ELECTRICAL CONNECTIONS	34
3.11	Metallic Junction Boxes	34
3.12	Non-Metallic Junction Boxes	35
3.2	TYPICAL WIRING DIAGRAMS	36
3.21	Single-Phase Parallel Connection	36
3.22	Delta Connection	37
3.23	Wye Connection	38
3.24	Multiple Wye Connections with APS Panel	39
3.25	Multiple Delta Connections with APS Panel	40
3.3	CONTROL OPTIONS	41
3.31	Automatic Snow Controllers	41
3.32	Slab Sensing Thermostat	41
3.33	Manual On/Off Control	41
3.4	REPAIRS	42

3.1 ELECTRICAL CONNECTIONS

Nuheat recommends using metallic junction boxes because the NPT threaded connector provides a ground path for the heating cable. If non-metallic (ie. PVC) junction boxes are used, ground bushings are required.

3.1.1 METALLIC JUNCTION BOXES

1. Pull back on the rubber shroud to expose connection pieces.
2. Screw a ½" lock nut onto the threaded connector.
3. Screw the threaded connector into the junction box. Ensure the pot extends slightly into the junction box.
4. Screw another ½" lock nut onto the threaded connector inside the junction box. Tighten the ½" lock nut to secure the connection. The pot should still be able to slide loosely inside the junction box.
5. Pull the cable from the outside of the junction box so that the pot is against the wall of the junction box.
6. Tighten the compression nut with a wrench to ensure the pot cannot slide loosely inside the junction box.
7. Push the rubber shroud back over the connection pieces. The rubber shroud should now fully encapsulate the bottom of the gland.

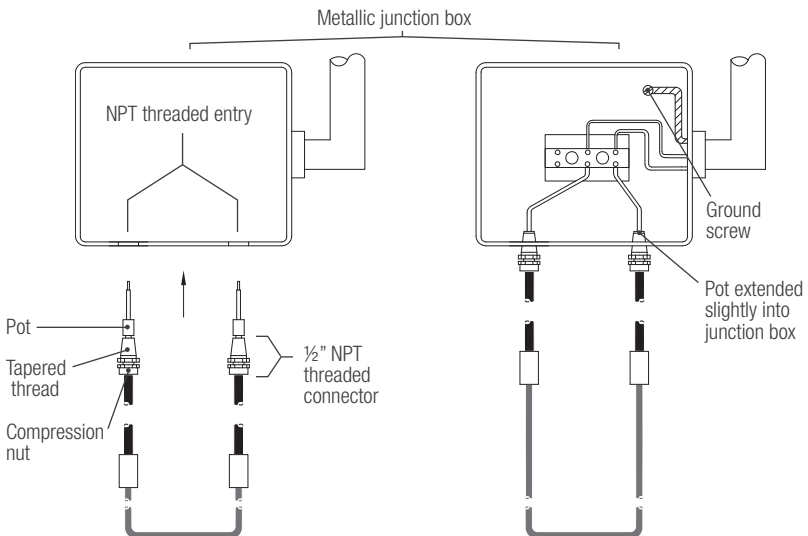

FIGURE 3.11: Securing the Cold Leads in Metallic Junction Box

3.1 ELECTRICAL CONNECTIONS

3.1.2 NON-METALLIC JUNCTION BOXES

1. Pull back on the rubber shroud to expose connection pieces.
2. Screw a 1/2" lock nut onto the threaded connector.
3. Screw the threaded connector into the junction box. Ensure the pot extends slightly into the junction box.
4. Screw the ground bushings onto the threaded connector inside the junction box. Tighten the ground bushing to secure the connection. The pot should still be able to slide loosely inside the junction box.
5. Pull the cable from the outside of the junction box so that the pot is against the wall of the junction box.
6. Tighten the compression nut with a wrench to ensure the pot cannot slide loosely inside the junction box.
7. Push the rubber shroud back over the connection pieces. The rubber shroud should now fully encapsulate the bottom of the gland.

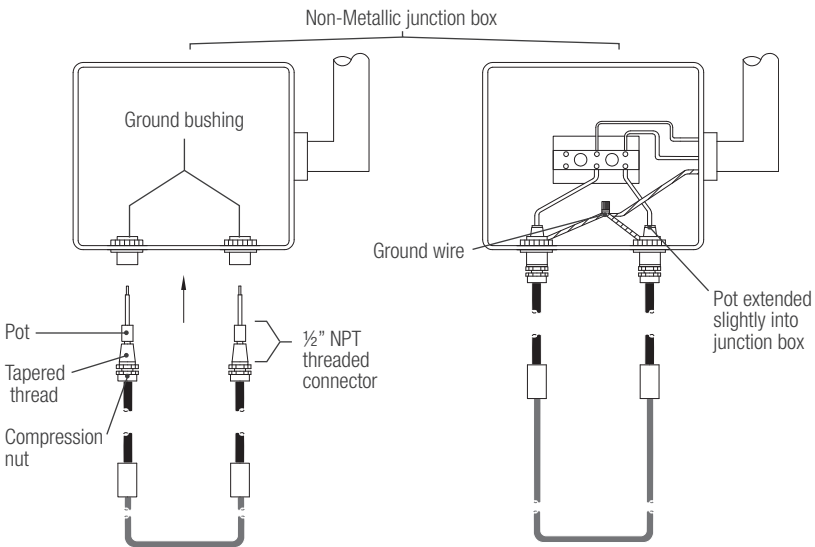
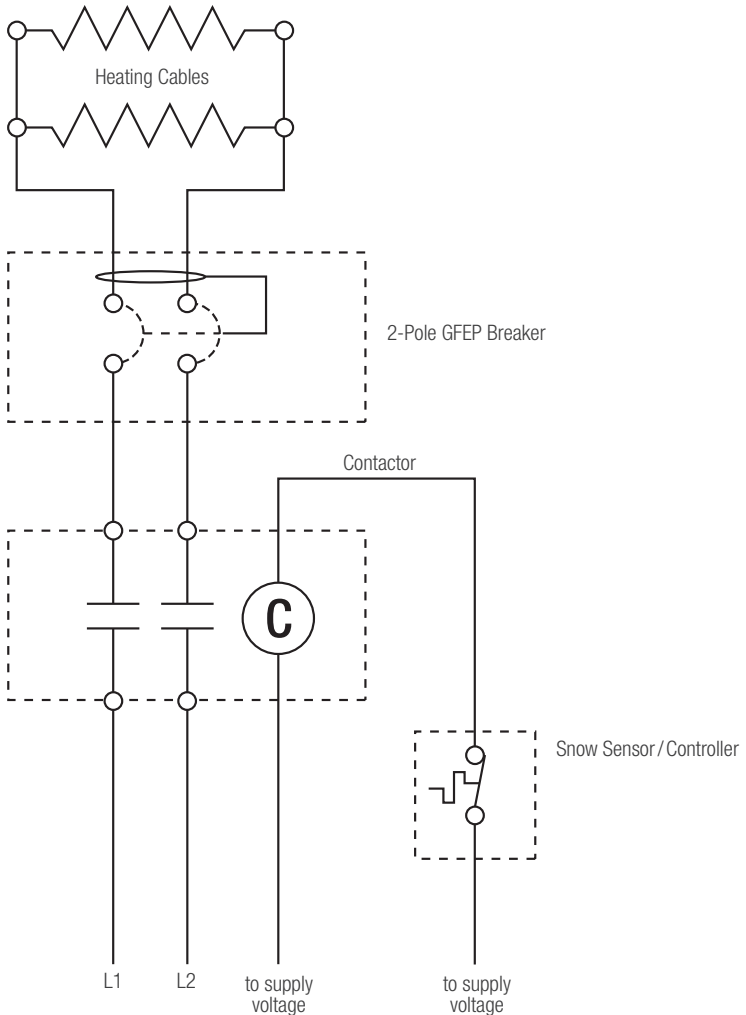

FIGURE 3.12: Securing the Cold Leads in Non-Metallic Junction Box

3.2 TYPICAL WIRING DIAGRAMS

The following are typical wiring diagrams for the Nuheat Weather-Ready™ MI Snow Melt Cable System. Wiring connections should only be made by qualified personnel familiar with industry standards for snow melting systems. Installation and wiring must be in accordance with local building codes.

3.2.1 SINGLE-PHASE PARALLEL CONNECTION



3.2 TYPICAL WIRING DIAGRAMS

3.22 DELTA CONNECTION

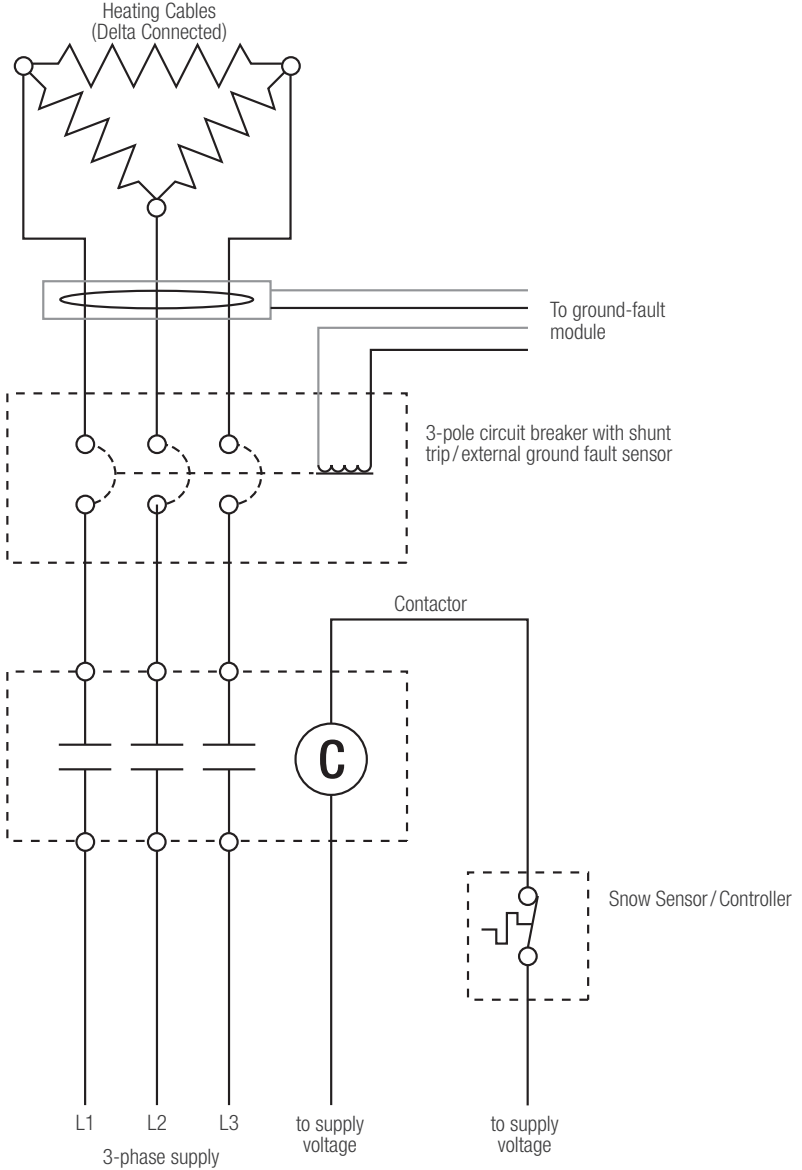

3.2 TYPICAL WIRING DIAGRAMS

3.23 WYE CONNECTION

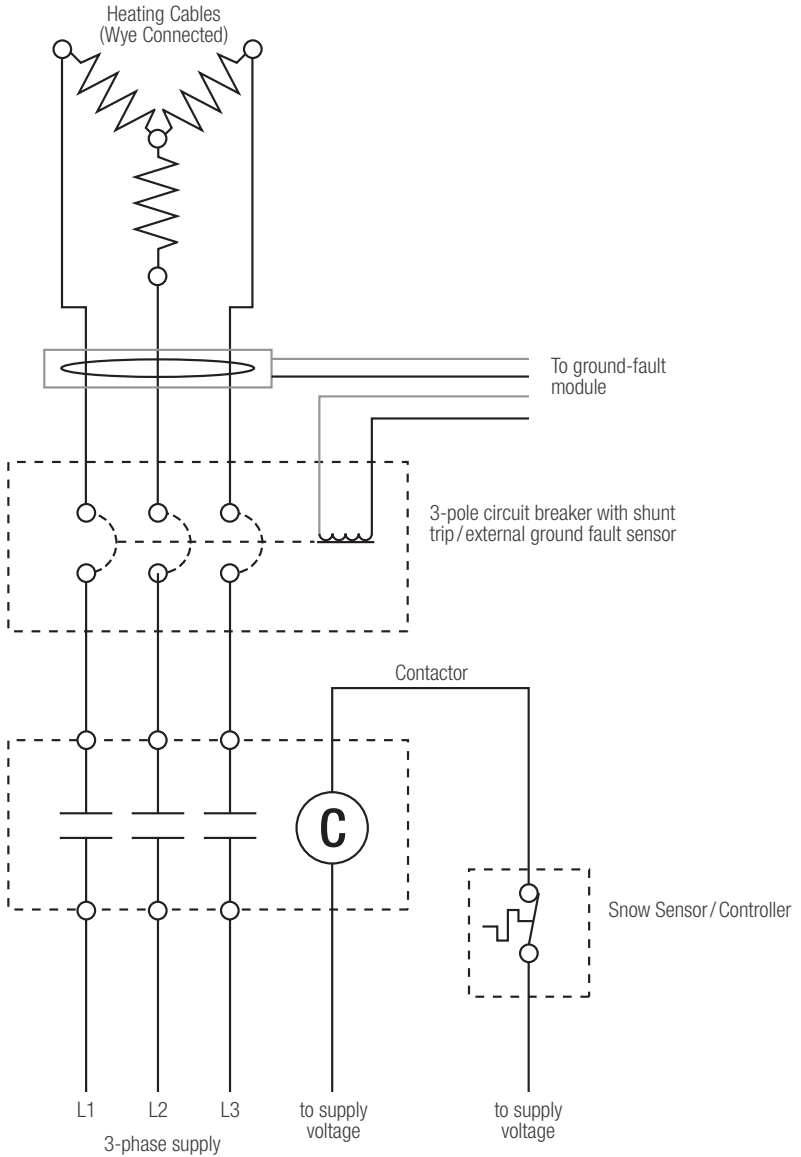

3.2 TYPICAL WIRING DIAGRAMS

3.2.4 MULTIPLE WYE CONNECTIONS WITH APS PANEL

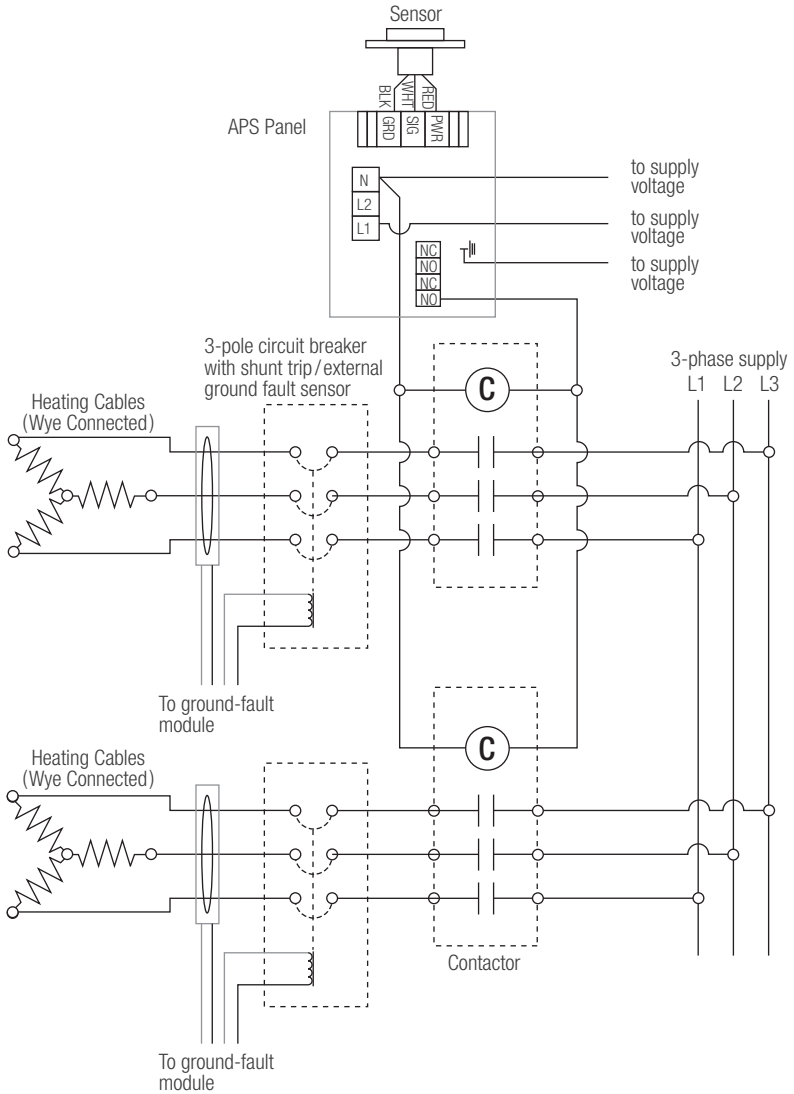

3.2 TYPICAL WIRING DIAGRAMS

3.25 MULTIPLE DELTA CONNECTIONS WITH APS PANEL

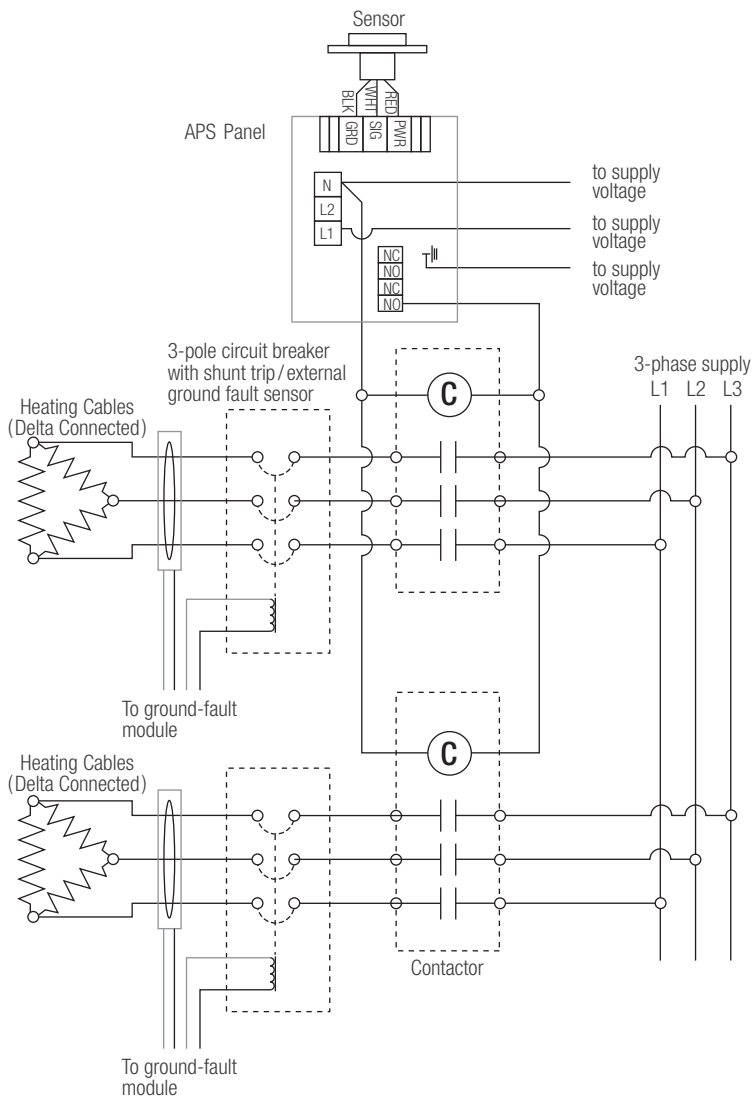

3.3 CONTROL OPTIONS

There are several options available to control the Nuheat Weather-Ready™ MI Snow Melt Cables. Consult the electrical contractor to determine the most suitable option. Selecting the proper control option will limit the power consumption of the snow melting system by turning on the heating cables only when it is needed.

3.31 AUTOMATIC SNOW CONTROLLER

- > Turns on the heating cable when both precipitation AND low temperatures are detected.
- > System remains “ON” once precipitation or low temperature have ceased, allowing the surface to completely dry, preventing the formation of surface ice.
- > When combined with a slab-sensing thermostat, the system will de-energize once the slab has reached the preset or user-defined temperature setpoint.
- > Using an automatic snow controller in conjunction with a slab-sensing thermostat offers the most energy efficient control solution.

3.32 SLAB-SENSING THERMOSTAT

- > Turns on the heating cable when the slab temperature drops below a preset or user-defined temperature (usually set at freezing point).
- > Highly recommended for asphalt and mastic asphalt applications to prevent surface from softening if heating cables are inadvertently left energized in warmer months.
- > Not energy efficient if used as a sole means of control. Slab temperature may be below freezing but no snowfall is present.
- > Option is more energy efficient when used in conjunction with an automatic snow controller.

3.V MANUAL ON/OFF CONTROL

- > Low initial cost.
- > Recommended only for small areas.
- > Requires manual monitoring.
- > Prone to be left on accidentally.

3.4 REPAIRS

If any part of the cable becomes damaged at any time, please contact Nuheat Customer Care Team immediately at 1.800.778.WARM(9276).



**Freeze
Protection
Products**

PIPE • ROOF & GUTTER • SLAB

Nuheat Freeze Protection Products
toll free 1.800.778.WARM (9276)
fax 604.529.4404
www.nuheat.com
info@nuheat.com



Nuheat™ is the registered Trademark of Nuheat Industries Ltd.

Printed in Canada

January 2014